

Ingersoll-Rand®

Air Motors



CONTENTS

Introduction Page 2-3

MULTI-VANE® Motor Series

M002 (.11 -.25HP)	4-6
M004 (.31-.50HP)	7-9
M007 (.61-.85HP)	10-13
1801 and 1841 (1.1-1.4HP)	14-15
3800 and 3840 (1.35-1.55HP)	16-17
4800 and 4840 (3-3.8HP)	18-19
17RA, 17RB, 34RA, 34RB (2.2-4.1HP)	20-21
48RA and 48RB (3-3.1 HP)	22-23
92RA and 92RB (7.9-8.15HP)	24-25
22N51 (1.75HP)	26
551 (5.6HP)	27

92RM and 992RM (8.15-9.9HP) 28-29

MRV (.33-4.8HP) 30-35

MVA and MOV0 (1.93-10.5HP) 36-39

Piston Motor Series (2.05-30HP)

Direct and Geared Drive (1.6-25HP) 40-44

KK5B Modular Piston Motors (29-30HP) 45-47

MMP150 48-49

Air Motor Selection and Characteristics 50-51

Varying Air Pressure 52

Air Motor Components and Equipment 53-55

“Special” Air Motors 55

IR AIR POWER

Creating sheer power from the natural environment, Ingersoll-Rand air motors are flexible, efficient alternatives to electric sources—perfect for a wide range of industrial applications. Consider these advantages:

- Infinitely variable speeds and torques via pressure regulation or air valves—no costly controls required
- Instant starting, stopping and reversing eliminates the delays of motor speed-up or slow-down periods
- Will not overheat or burn out, even when overloaded or run to stall
- Safe operation in hazardous conditions, with no electrical sparks or hydraulic fluids
- Cool running characteristics minimize the effects of hot, wet or dusty surroundings
- Low maintenance, based on simplicity of design and strength of construction
- Excellent design flexibility—a function of compact size, light weight, and high power output
- Temperature range—up to 150°F with standard lubrication and up to 300°F with high temperature lubrication

A FULL SPECTRUM OF SOLUTIONS

Ingersoll-Rand offers well over 170 cataloged models of air motors, with an extensive range of options:

- Reversible and non-reversible types
- 0.11 to 30 horsepower
- Square drive shafts (available on series M002, M004, M007, 1801, 1841, 3800, 3840, 4800 and 4840)
- Vane or piston configurations
- 23 rpm to 12,250 rpm speed ratings
- Geared and non-geared varieties
- 0.18 ft-lb. to 1090 ft-lb. torque ratings

In addition, Ingersoll-Rand maintains data on hundreds of special application air motors that have solved problems for design engineers around the world over the years. You can access this invaluable resource by contacting your Ingersoll-Rand representative or distributor with details of your situation.

With over 125 years of engineering and manufacturing leadership, Ingersoll-Rand is the expert in air power.

I-R AIR MOTOR PERFORMANCE CURVES

The performance curves shown throughout this catalog can assist you in matching specific air motor models to requirements. Performance data within one series may vary slightly, depending on gear ratios. When this occurs, median performance for that series is indicated. Follow these guidelines for interpreting the performance curves:

Horsepower

1. Locate operating speed on the correct horizontal axis of the bottom chart
2. Read Horsepower from the correct curve in the bottom chart

Torque

1. Locate operating speed on the correct horizontal axis of the bottom chart
2. Read Torque from the correct curve in the bottom chart

Air Consumption

1. Locate operating speed on the correct horizontal axis on the bottom chart
2. Read Air Consumption from the correct curve in the top chart

Maximum Allowable Shaft Radial Load

On applications where Shaft Radial Load is a factor:

1. Locate operating speed on the horizontal axis of the top chart
2. Read Shaft Radial Load on the correct Load Curve in the top chart

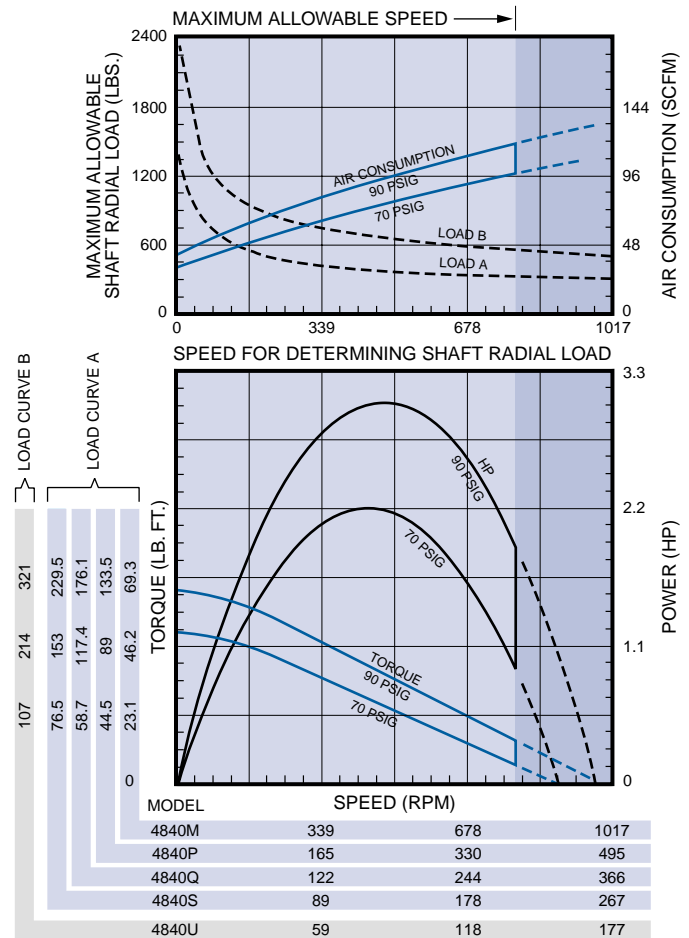

Two 1/3 Horsepower Motors

The Ingersoll-Rand reversible Series M004 Air Motor shown weighs only 2 3/8 lbs. It has integral gear reduction of 33 to 1 and a free speed of 450 rpm. The comparable horsepower 110 volt electric motor, with a free speed of 1725 rpm, weighs 15 1/2 lbs.

ISO

9001

CERTIFIED

SERIES M002 MULTI-VANE AIR MOTORS

Round Keyed Shaft • Square Shaft (Optional) • Threaded Shaft (Optional)
 .11 to .25 hp • Flange Mounted

SPECIFICATIONS

Model	Max. Power		Speed at Max. Power	Free Speed▲	Starting Torque		Stall Torque		Air Consumption at Max. Power		Weight	
	hp	kw	rpm	rpm	lb.-ft.	Nm	lb.-ft.	Nm	scfm	m ³ /m	lb.	kg
Non-Reversible Direction of rotation is counterclockwise when facing the shaft.												
M002RHR000AR3	0.25	0.19	12,250	26,000	0.15	0.20	0.20	0.27	12.0	0.34	1	0.46
M002RHR004AR3	0.22	0.16	3250	6920	0.45	0.61	0.61	0.83	11.9	0.34	1	0.46
M002RHR006AR3	0.22	0.16	2060	4385	0.72	0.98	0.96	1.30	11.9	0.34	1½	0.49
M002RHR008AR3	0.22	0.16	1520	3240	0.98	1.33	1.31	1.78	11.9	0.34	1	0.46
M002RHR013AR3	0.19	0.14	880	1840	1.36	2.50	1.82	2.47	11.8	0.33	1½	0.50
M002RHR021AR3	0.19	0.14	555	1165	2.16	2.93	2.88	3.90	11.8	0.33	1½	0.50
M002RHR028AR3	0.19	0.14	410	860	2.92	3.96	3.90	5.29	11.8	0.33	1½	0.50
M002RHR044AR3	0.19	0.14	262	545	4.61	6.25	6.15	8.34	11.8	0.33	1½	0.50
M002RHR101AR3	0.16	0.12	112	228	*8.32	*11.2	*11.1	*15.0	11.7	0.33	1¾	0.54
M002RHR159AR3	0.16	0.12	71	145	*13.1	*17.7	*17.5	*23.7	11.7	0.33	1¾	0.54
Reversible												
M002RVR000AR3	0.20	0.15	11,500	23,000	0.13	0.18	0.18	0.24	9.8	0.28	1	0.46
M002RVR004AR3	0.17	0.13	3045	6090	0.40	0.54	0.54	0.73	9.7	0.27	1	0.46
M002RVR006AR3	0.17	0.13	1930	3860	0.64	0.87	0.86	1.17	9.7	0.27	1½	0.49
M002RVR008AR3	0.17	0.13	1425	2850	0.87	1.18	1.16	1.57	9.7	0.27	1	0.46
M002RVR013AR3	0.14	0.10	820	1645	1.17	1.58	1.56	2.11	9.6	0.27	1½	0.50
M002RVR021AR3	0.14	0.10	520	1045	1.85	2.51	2.47	3.35	9.6	0.27	1½	0.50
M002RVR028AR3	0.14	0.10	385	770	2.50	3.39	3.34	4.53	9.6	0.27	1½	0.50
M002RVR044AR3	0.14	0.10	240	485	3.96	5.37	5.28	7.16	9.6	0.27	1½	0.50
M002RVR101AR3	0.11	0.08	104	209	*6.78	*9.19	*9.05	*12.2	9.5	0.27	1¾	0.54
M002RVR159AR3	0.11	0.08	66	132	*10.7	*14.5	*14.2	*19.3	9.5	0.27	1¾	0.54

▲ ALL models must be operated with sufficient load to prevent speed from exceeding maximum allowable speed shown on performance curve.

* Applications with these models must be limited to 12 lb.-ft. (16.3 Nm) torque.

Performance figures are at 90 psig (620 kPa) air pressure.

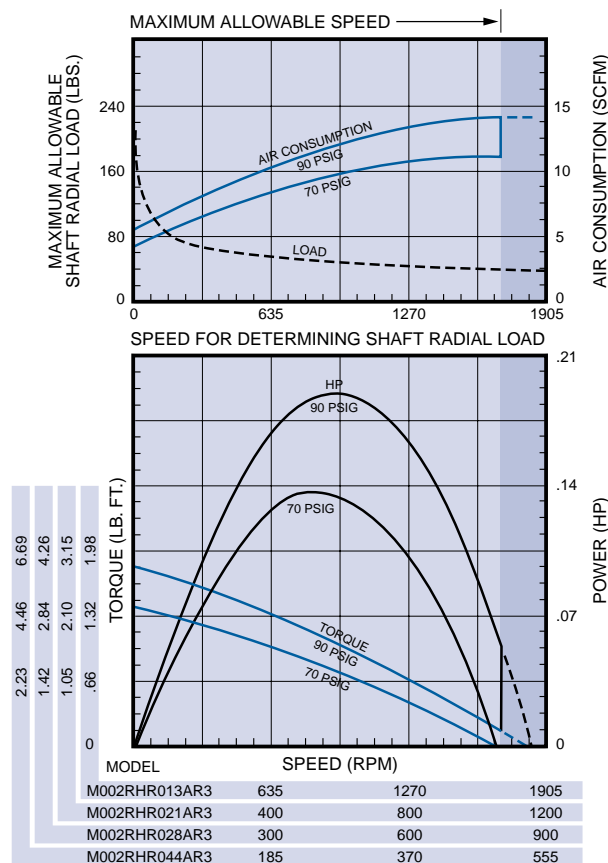
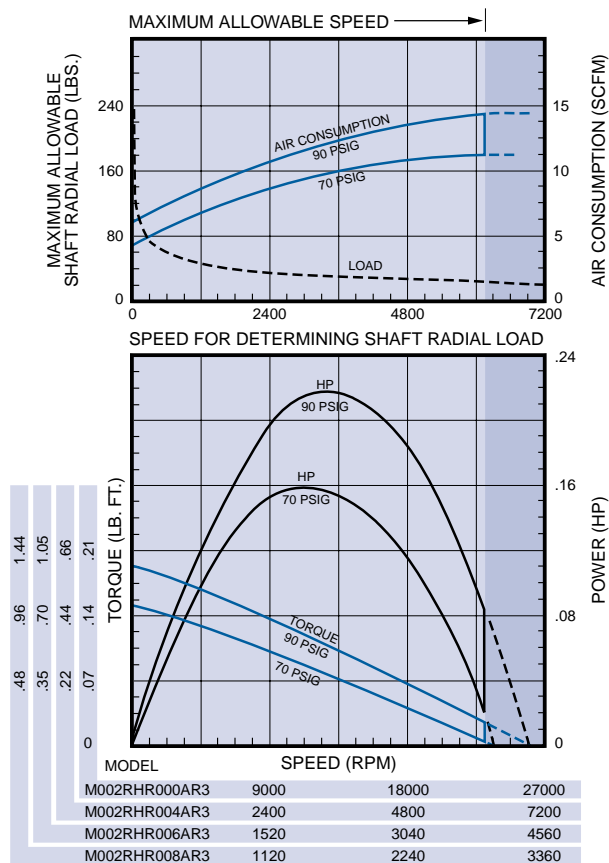

SERIES M002 MULTI-VANE AIR MOTORS

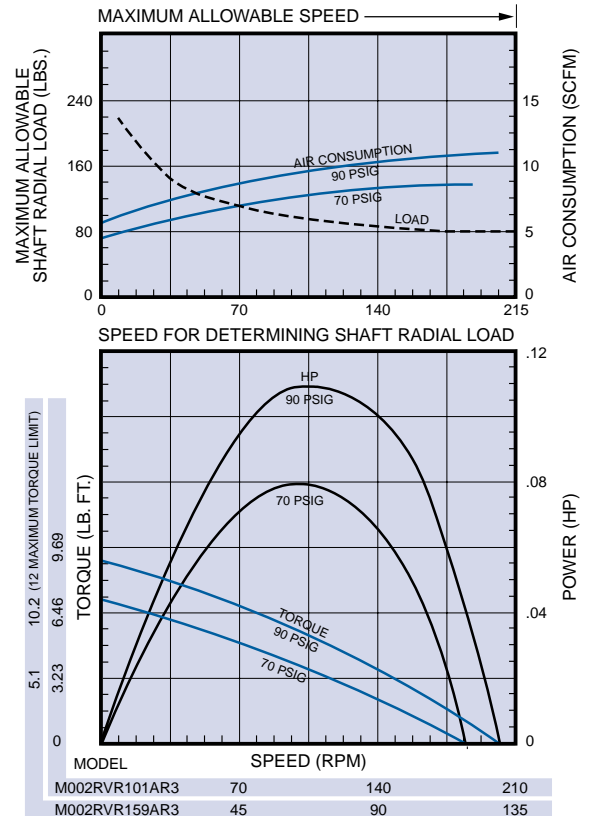
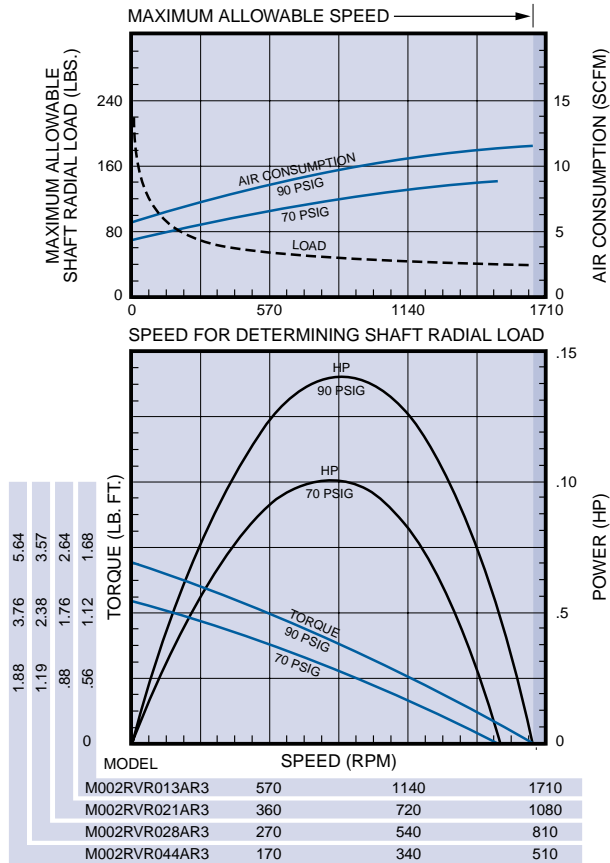
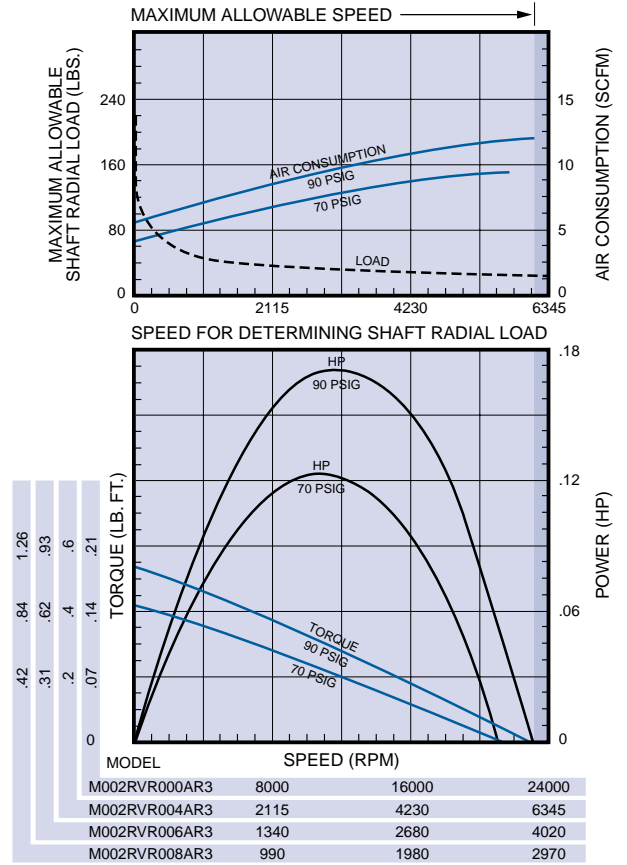
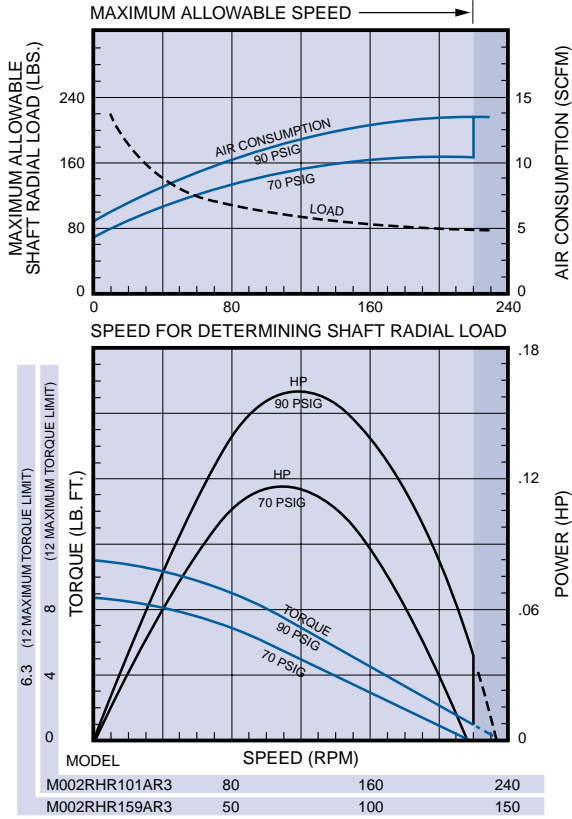
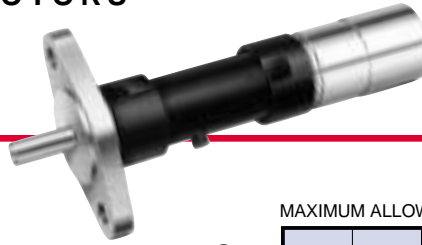

SERIES M002 MULTI-VANE AIR MOTORS

SERIES M002 DIMENSIONS

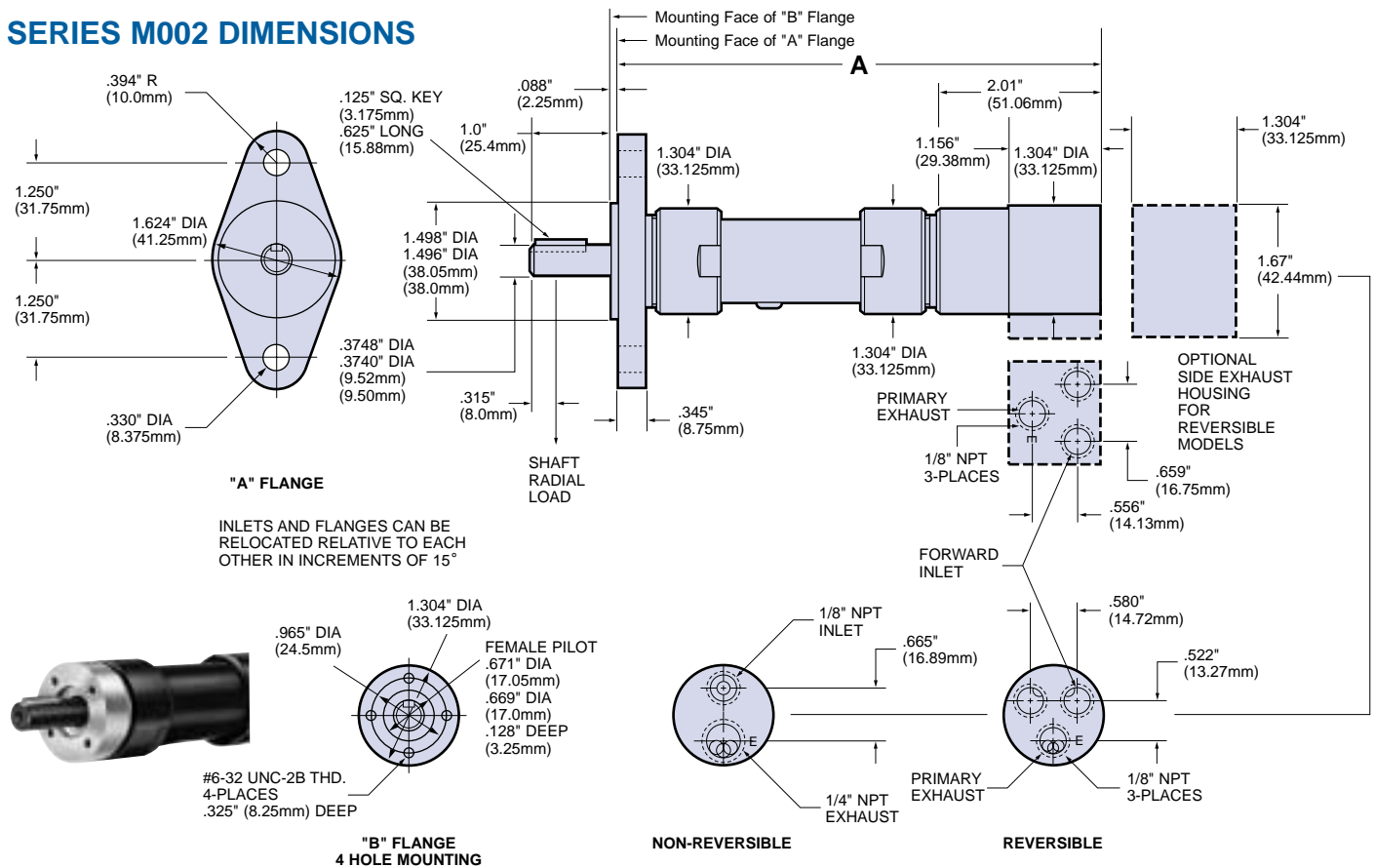

SERIES M002 MODEL NUMBER SYMBOLIZATION

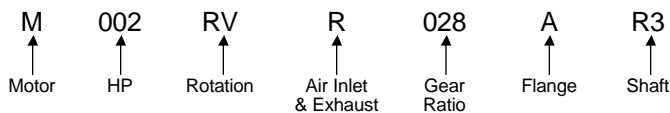

HP = Approximate horsepower range (.11 to .25)

Rotation = RV Reversible
 RH Non-Reversible, Right Hand from Rear of Motor (CCW facing shaft)
 LH Non-Reversible, Left Hand from Rear of Motor (CW facing shaft)

Air Inlet & Exhaust = R Rear, S Side (Side Inlet and Exhaust available on Reversible Models only)

Gear Ratio = 028 is 1 to 28, 044 is 1 to 44, etc.

Flange = A 2 Hole Flange, B 4 Hole Face Mounting

Shaft = R3 3/8" Round Keyed
 T3 3/8"-24 UNF-2A Threaded.
 Threaded Shaft Extension is 1" (25.4mm) with Threaded Length from Shaft End of .87" (22mm).
 Threaded Shaft Pilot at End is .315" (8mm) Dia. Max. by .374" (9.5mm) Long
 S3 3/8" Square Drive
 Square Shaft Extension is 1.791" (45.5mm)

DIMENSIONS

Gear Ratios (Refer to Model No.)	A	
	in.	mm
000, 004, 008	4.989	126.73
006, 013, 021, 028, 044	5.510	139.93
101, 159	6.020	152.91

EQUIPMENT OPTIONS

Furnished with Cataloged Models	Optional at No Extra Price	Optional at Extra Price
2 Hole Flange Mounting	4 Hole Face Mounting	R1440-212-1 3/8" Square Drive Adapter, 1" long with 3/8" -24 Female threads for use with Threaded Shaft.
3/8" Round Keyed Shaft	3/8"-24 Threaded Shaft	Required for 3/8" Adapter (2) R2J-561 set screws (1) 8U-722 Bail
	Side Inlet and Exhaust Housing (for Reversible Models only)	

Note: On all Series M002, M004, and M007 Air Motors, performance is the same for both directions of rotation. On Non-Reversible models, direction of rotation may be easily changed without the need of additional parts by inverting cylinder. See Assembly Instruction form number listed in price sheet.

SERIES M004 MULTI-VANE AIR MOTORS

Round Keyed Shaft • Square Shaft (Optional) • Threaded Shaft (Optional)
 .31 to .50 hp • Geared Drive • Flange Mounted



SPECIFICATIONS

Model	Max. Power		Speed at Max. Power	Free Speed▲	Starting Torque		Stall Torque		Air Consumption at Max. Power		Weight	
	hp	kw	rpm	rpm	lb.-ft.	Nm	lb.-ft.	Nm	scfm	m ³ /m	lb.	kg
Non-Reversible Direction of rotation is counterclockwise when facing the shaft.												
M004RHR000AR3	0.50	0.37	10,000	18,000	0.40	0.54	0.53	0.72	20.0	0.57	2 ¹ / ₁₆	0.95
M004RHR004AR3	0.47	0.35	2470	4450	1.46	1.98	1.94	2.63	19.5	0.55	2 ¹ / ₁₆	1.00
M004RHR006AR3	0.47	0.35	1490	2680	2.42	3.28	3.22	4.37	19.5	0.55	2 ¹ / ₁₆	1.00
M004RHR011AR3	0.44	0.33	825	1490	3.92	5.32	5.22	7.08	19.0	0.54	2 ¹ / ₁₆	1.09
M004RHR015AR3	0.44	0.33	610	1095	5.32	7.21	7.10	9.63	19.0	0.54	2 ¹ / ₁₆	1.09
M004RHR023AR3	0.44	0.33	395	715	8.10	11.0	10.8	14.6	19.0	0.54	2 ¹ / ₁₆	1.09
M004RHR033AR3	0.44	0.33	280	505	11.5	15.6	15.4	20.8	19.0	0.54	2 ¹ / ₁₆	1.09
M004RHR050AR3	0.41	0.31	175	315	*16.5	*22.4	*22.1	*30.0	18.5	0.52	2 ¹ / ₁₆	1.22
M004RHR083AR3	0.41	0.31	106	190	*27.5	*37.3	*36.7	*49.7	18.5	0.52	2 ¹ / ₁₆	1.22
M004RHR167AR3	0.41	0.31	53	95	*55.0	*74.5	*73.3	*99.4	18.5	0.52	2 ¹ / ₁₆	1.22
Reversible												
M004RVR000AR3	0.40	0.30	8000	16,000	0.32	0.43	0.42	0.57	19.0	0.54	2 ¹ / ₁₆	0.95
M004RVR004AR3	0.37	0.28	1975	3955	1.13	1.53	1.51	2.05	18.5	0.52	2 ¹ / ₁₆	1.00
M004RVR006AR3	0.37	0.28	1190	2380	1.88	2.55	2.51	3.40	18.5	0.52	2 ¹ / ₁₆	1.00
M004RVR011AR3	0.34	0.25	660	1325	3.00	4.07	4.00	5.42	18.0	0.51	2 ¹ / ₁₆	1.09
M004RVR015AR3	0.34	0.25	485	975	4.07	5.52	5.43	7.36	18.0	0.51	2 ¹ / ₁₆	1.09
M004RVR023AR3	0.34	0.25	315	635	6.23	8.45	8.30	11.2	18.0	0.51	2 ¹ / ₁₆	1.09
M004RVR033AR3	0.34	0.25	225	450	8.85	12.0	11.8	16.0	18.0	0.51	2 ¹ / ₁₆	1.09
M004RVR050AR3	0.31	0.23	140	280	*12.3	*16.7	*16.5	*22.4	17.5	0.50	2 ¹ / ₁₆	1.22
M004RVR083AR3	0.31	0.23	84	169	*20.6	*27.9	*27.5	*37.3	17.5	0.50	2 ¹ / ₁₆	1.22
M004RVR167AR3	0.31	0.23	42	85	*41.3	*56.0	*55.0	*74.5	17.5	0.50	2 ¹ / ₁₆	1.22

▲ ALL models must be operated with sufficient load to prevent speed from exceeding maximum allowable speed shown on performance curve.

* Applications with these models must be limited to 33 lb.-ft. (44.7 Nm) torque.

Performance figures are at 90 psig (620 kPa) air pressure.

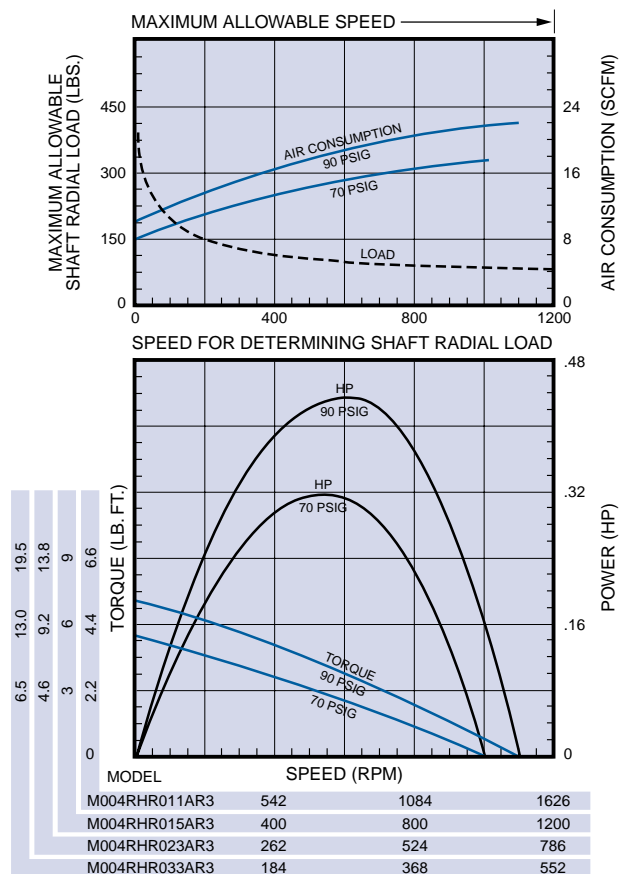
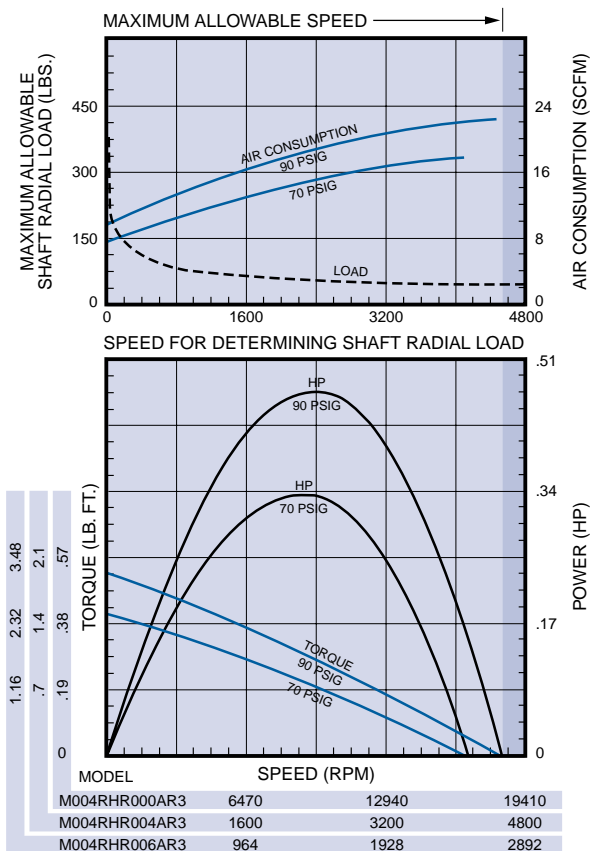

SERIES M004 MULTI-VANE AIR MOTORS

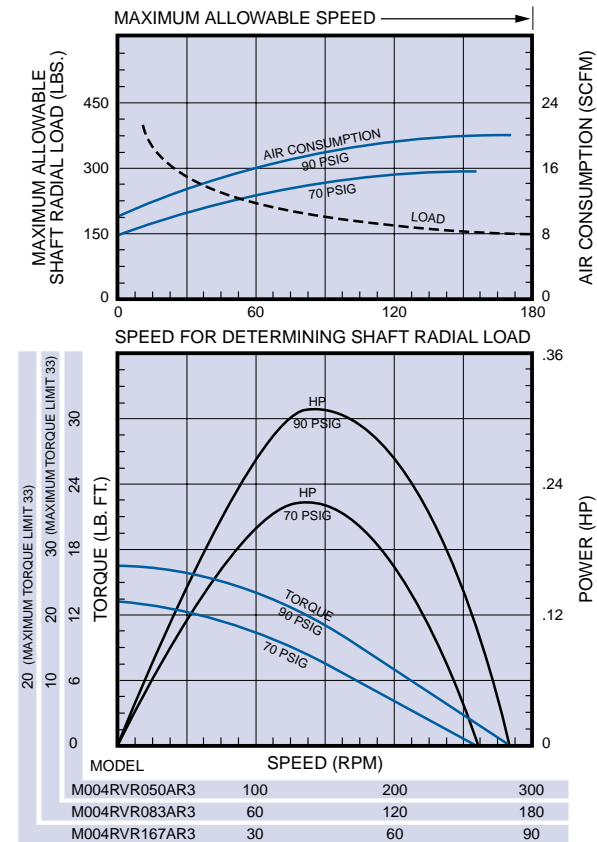
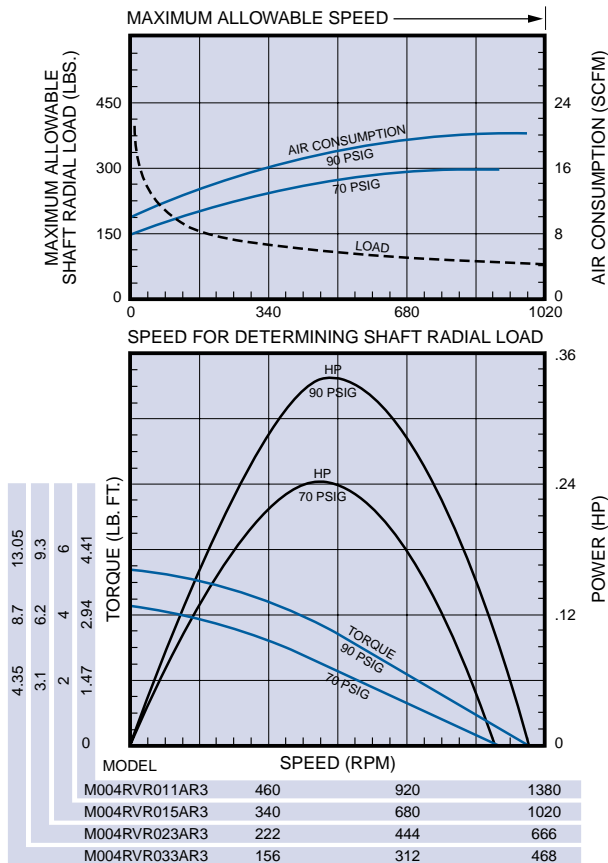
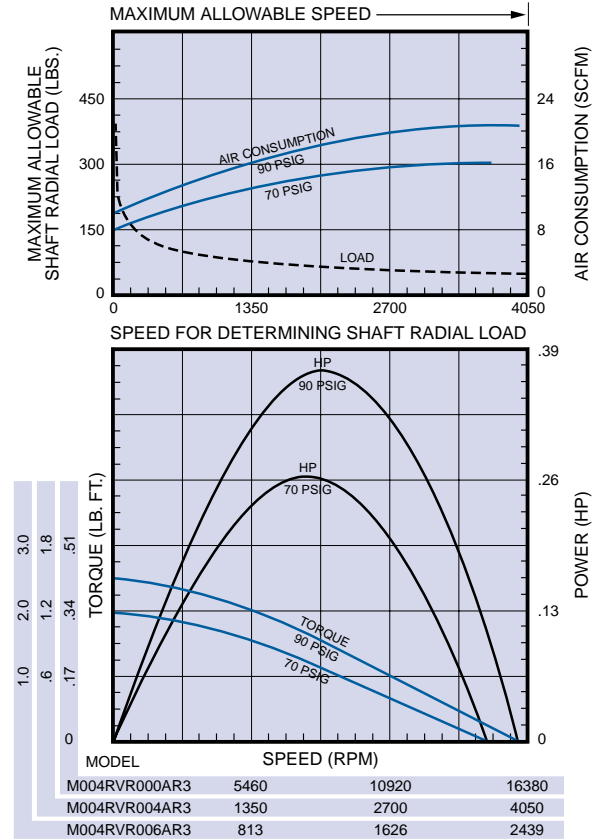
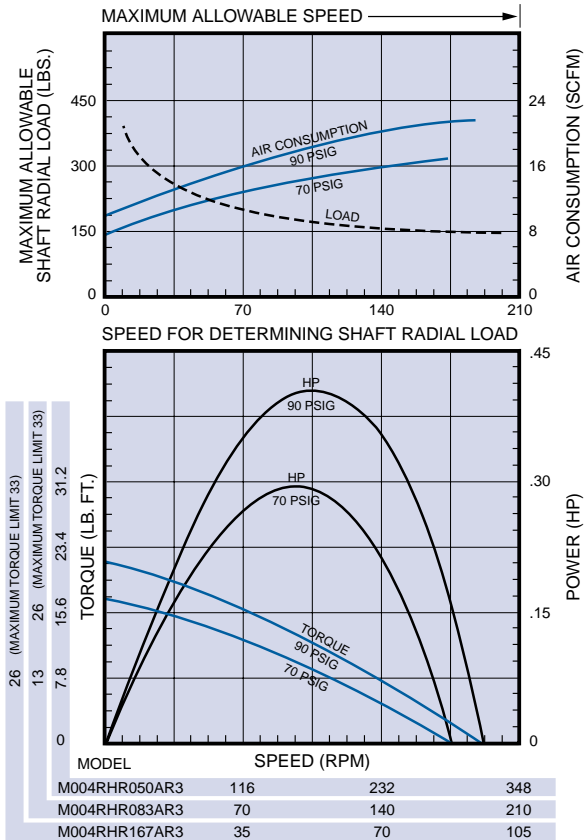

SERIES M004 MULTI-VANE AIR MOTORS



SERIES M004 DIMENSIONS

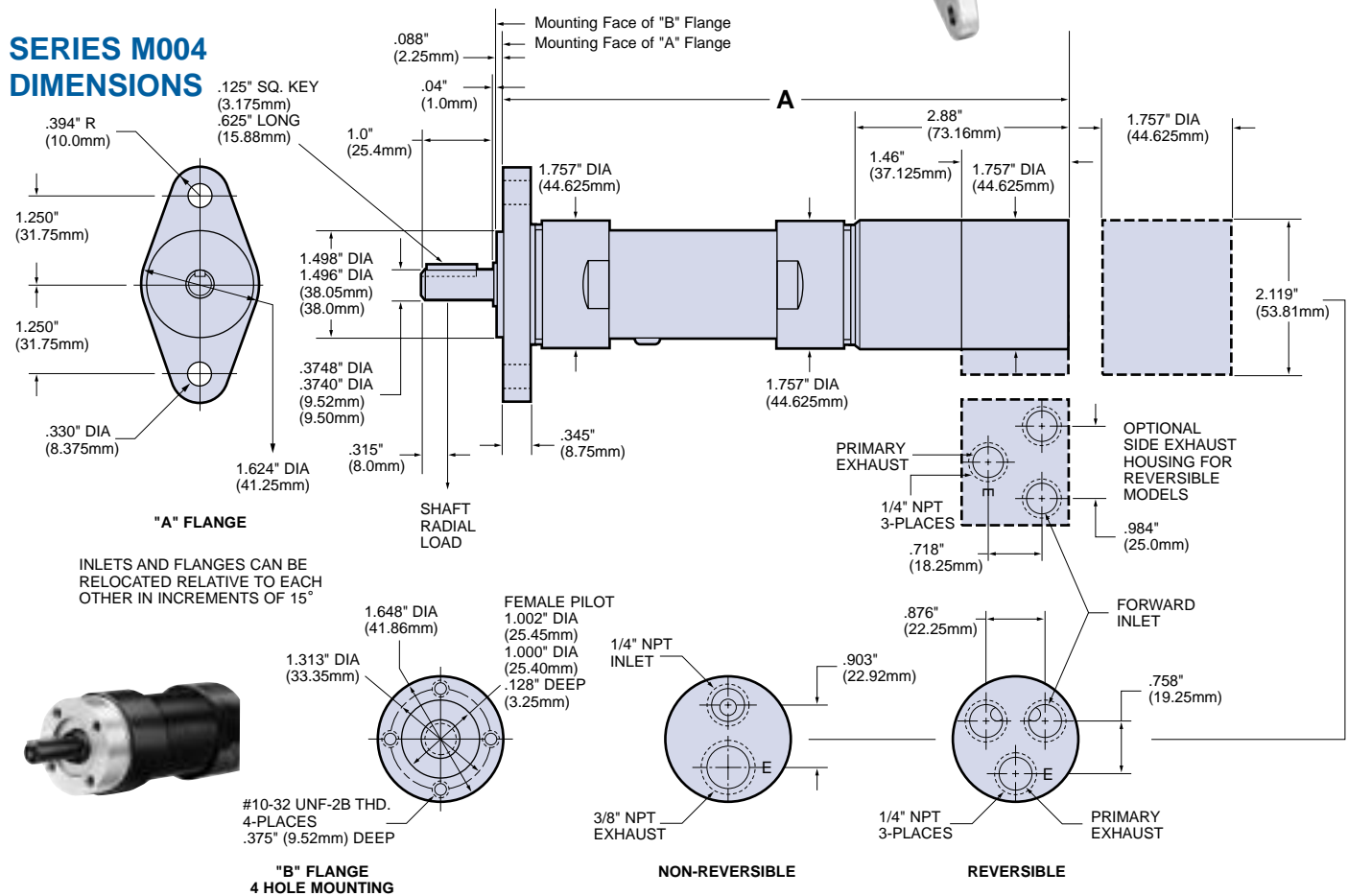

SERIES M004 MODEL NUMBER SYMBOLIZATION

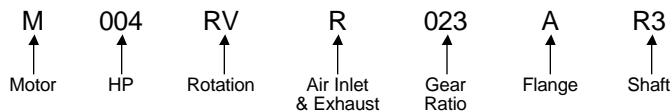

HP = Approximate horsepower range (.31 to .50)

Rotation = RV Reversible
 RH Non-Reversible, Right Hand from Rear of Motor (CCW facing shaft)
 LH Non-Reversible, Left Hand from Rear of Motor (CW facing shaft)

Air Inlet & Exhaust = R Rear, S Side (Side Inlet and Exhaust available on Reversible Models only)

Gear Ratio = 023 is 1 to 23, 033 is 1 to 33, etc.

Flange = A 2 Hole Flange, B 4 Hole Face Mounting

Shaft = R3 3/8" Round Keyed
 T3 3/8"-24 UNF-2A Threaded
 Threaded Shaft Extension is .512" (13mm)
 Full Thread Length is .424" (10.75mm)
 S3 3/8" Square Drive
 Square Shaft Extension is 1.791" (45.5mm)

DIMENSIONS

Gear Ratios (Refer to Model No.)	A	
	in.	mm
000, 004, 006	6.248	158.69
011, 015, 023, 033	6.984	177.38
050, 083, 167	7.745	196.73

EQUIPMENT OPTIONS

Furnished with Cataloged Models	Optional at No Extra Price	Optional at Extra Price
2 Hole Flange Mounting	4 Hole Face Mounting	R1440-212-1 3/8" Square Drive Adapter, 1" long with 3/8" -24 Female threads for use with Threaded Shaft.
3/8" Round Keyed Shaft	3/8"-24 Threaded Shaft	Required for 3/8" Adapter (2) R2J-561 set screws
	Side Inlet and Exhaust Housing (for Reversible Models only)	

Note: On all Series M002, M004, and M007 Air Motors, performance is the same for both directions of rotation. On Non-Reversible models, direction of rotation may be easily changed without the need of additional parts by inverting cylinder. See Assembly Instruction form number listed in price sheet.

SERIES M007 MULTI-VANE AIR MOTORS

Round Keyed Shaft • Square Shaft (Optional) • .61 to .85 hp • Geared Drive
Flange or Face Mounted

SPECIFICATIONS

Model	Max. Power		Speed at Max. Power	Free Speed▲	Starting Torque		Stall Torque		Air Consumption at Max. Power		Weight	
	hp	kw	rpm	rpm	lb.-ft.	Nm	lb.-ft.	Nm	scfm	m ³ /m	lb.	kg
Non-Reversible Direction of rotation is counterclockwise when facing the shaft.												
M007RHR000AR4	0.85	0.63	11,000	22,000	0.58	0.79	0.77	1.04	36	1.02	3 ¹ / ₆	1.4
M007RHR004AR4	0.82	0.61	2445	4890	2.39	3.24	3.19	4.33	36	1.02	3 ¹ / ₆	1.4
M007RHR006AR4	0.82	0.61	1675	3350	3.50	4.75	4.66	6.32	36	1.02	3 ¹ / ₆	1.4
M007RHR009AR4	0.82	0.61	1230	2460	4.76	6.45	6.34	8.60	36	1.02	3 ¹ / ₆	1.4
M007RHR012AR4	0.79	0.59	870	1740	6.19	8.39	8.25	11.2	36	1.02	3 ¹ / ₂	1.6
M007RHR015AR4	0.79	0.59	685	1370	7.80	10.6	10.4	14.1	36	1.02	3 ¹ / ₂	1.6
M007RHR021AR4	0.79	0.59	470	940	11.5	15.6	15.3	20.7	36	1.02	3 ¹ / ₂	1.6
M007RHR027AR4	0.79	0.59	370	740	14.5	19.7	19.3	26.2	36	1.02	3 ¹ / ₂	1.6
M007RHR037AR4	0.79	0.59	270	540	19.7	26.7	26.3	35.7	36	1.02	3 ¹ / ₂	1.6
M007RHR044AR4	0.79	0.59	232	465	23.2	31.5	30.9	41.9	36	1.02	3 ¹ / ₂	1.6
M007RHR063BR6	0.79	0.59	161	321	33.5	45.4	44.7	60.6	36	1.02	7 ¹ / ₆	3.2
M007RHR086BR6	0.79	0.59	118	236	45.7	62.0	60.9	82.6	36	1.02	7 ¹ / ₆	3.2
M007RHR119BR6	0.76	0.57	82	163	60.5	82.0	80.7	109.0	36	1.02	7 ¹ / ₆	3.4
M007RHR151BR6	0.76	0.57	65	129	76.5	104.0	102.0	138.0	36	1.02	7 ¹ / ₆	3.4
M007RHR188BR6	0.76	0.57	52	103	96.0	130.0	128.0	174.0	36	1.02	7 ¹ / ₆	3.4
M007RHR275BR6	0.76	0.57	35	70	*140.0	*190.0	*187.0	*254.0	36	1.02	7 ¹ / ₆	3.4
M007RHR374BR6	0.76	0.57	26	52	*191.0	*259.0	*254.0	*344.0	36	1.02	7 ¹ / ₆	3.4
Reversible												
M007RVR000AR4	0.70	0.52	10,000	20,000	0.47	0.64	0.63	0.85	33	0.93	3 ¹ / ₆	1.4
M007RVR004AR4	0.67	0.50	2225	4450	1.94	2.63	2.59	3.51	33	0.93	3 ¹ / ₆	1.4
M007RVR006AR4	0.67	0.50	1520	3045	2.84	3.85	3.78	5.13	33	0.93	3 ¹ / ₆	1.4
M007RVR009AR4	0.67	0.50	1120	2240	3.86	5.23	5.14	6.97	33	0.93	3 ¹ / ₆	1.4
M007RVR012AR4	0.64	0.48	790	1580	4.97	6.74	6.63	8.99	33	0.93	3 ¹ / ₂	1.6
M007RVR015AR4	0.64	0.48	625	1250	6.29	8.53	8.38	11.4	33	0.93	3 ¹ / ₂	1.6
M007RVR021AR4	0.64	0.48	425	855	9.2	12.5	12.2	16.5	33	0.93	3 ¹ / ₂	1.6
M007RVR027AR4	0.64	0.48	335	675	11.6	15.7	15.5	20.1	33	0.93	3 ¹ / ₂	1.6
M007RVR037AR4	0.64	0.48	245	495	15.8	21.4	21.1	28.6	33	0.93	3 ¹ / ₂	1.6
M007RVR044AR4	0.64	0.48	210	420	18.6	25.2	24.8	33.6	33	0.93	3 ¹ / ₂	1.6
M007RVR063BR6	0.64	0.48	146	292	26.9	36.5	35.9	48.7	33	0.93	7 ¹ / ₆	3.2
M007RVR086BR6	0.64	0.48	107	215	36.7	49.8	48.9	66.3	33	0.93	7 ¹ / ₆	3.2
M007RVR119BR6	0.61	0.46	74	148	48.1	65.3	64.1	87.0	33	0.93	7 ¹ / ₆	3.4
M007RVR151BR6	0.61	0.46	58	117	61.0	82.7	81.3	110.0	33	0.93	7 ¹ / ₆	3.4
M007RVR188BR6	0.61	0.46	47	94	76.5	104.0	102.0	138.0	33	0.93	7 ¹ / ₆	3.4
M007RVR275BR6	0.61	0.46	32	64	*111.0	*151.0	*148.0	*201.0	33	0.93	7 ¹ / ₆	3.4
M007RVR374BR6	0.61	0.46	23	47	*152.0	*206.0	*202.0	*274.0	33	0.93	7 ¹ / ₆	3.4

▲ ALL models must be operated with sufficient load to prevent speed from exceeding maximum allowable speed shown on performance curve.

* Applications with these models must be limited to 224 lb.-ft. (304 Nm) torque.

Performance figures are at 90 psig (620 kPa) air pressure.

Note: On all Series M002, M004, and M007 Air Motors, performance is the same for both directions of rotation. On Non-Reversible models, direction of rotation may be easily changed without the need of additional parts by inverting cylinder. See Assembly Instruction form number listed in price sheet.

SERIES M007 MULTI-VANE AIR MOTORS

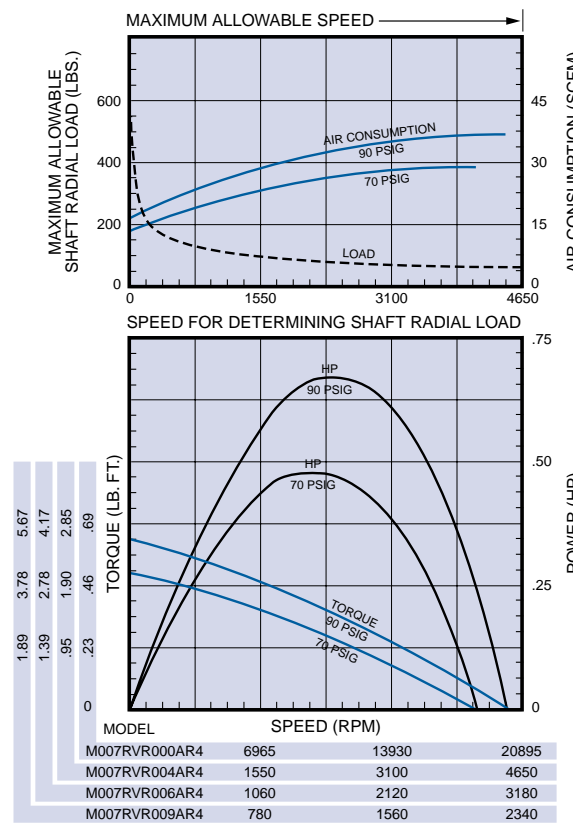
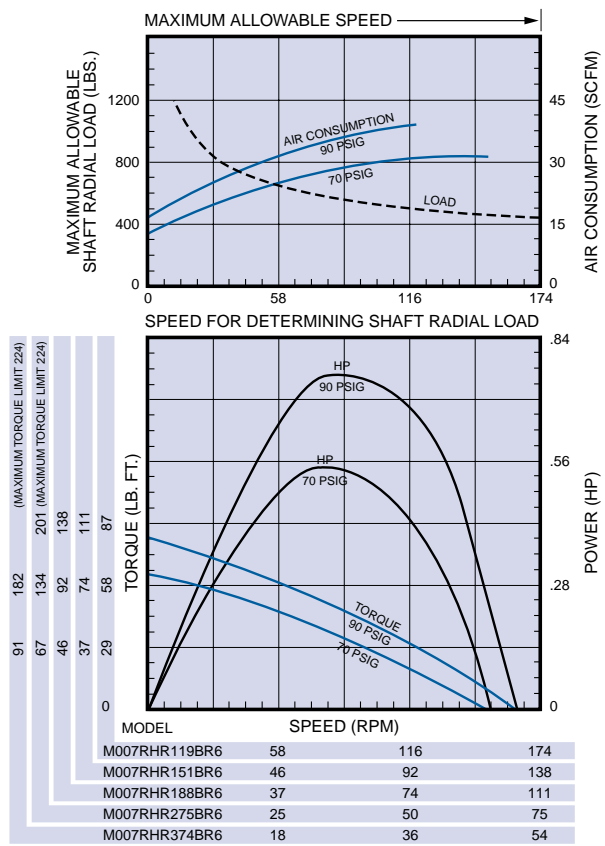
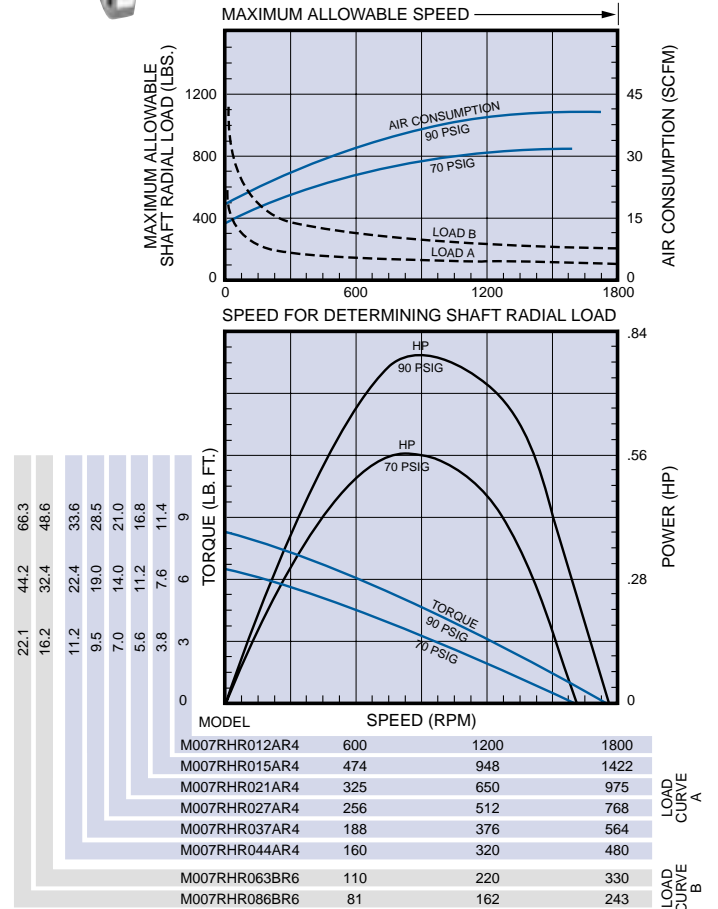
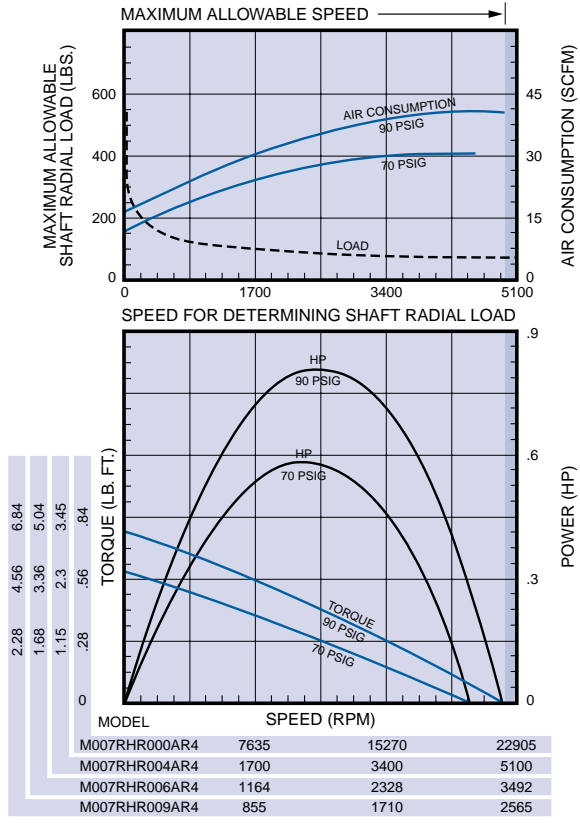

SERIES M007 MULTI-VANE AIR MOTORS

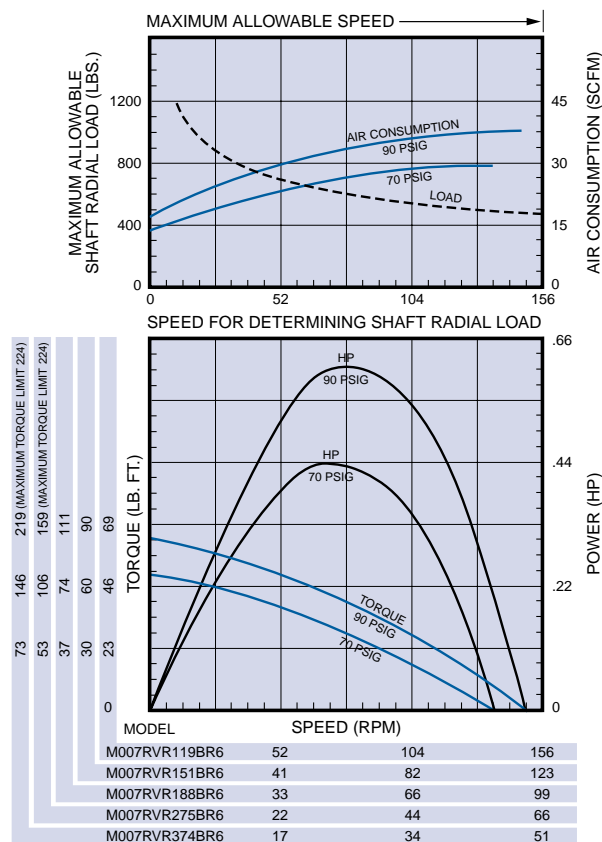
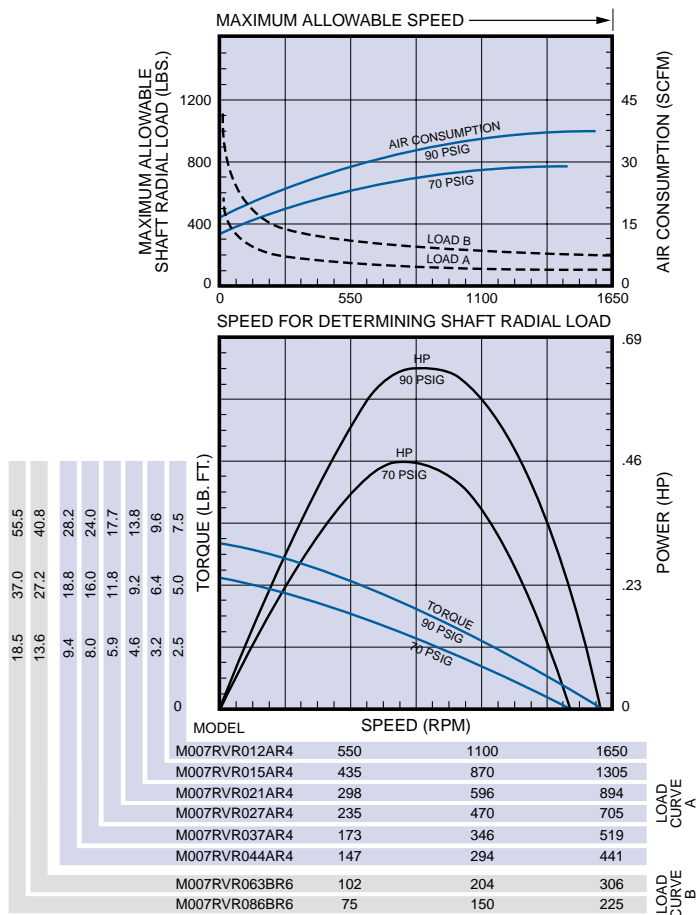

EQUIPMENT OPTIONS

Furnished with Cataloged Models	Optional at No Extra Price	Optional at Extra Price
2 Hole Flange Mounting on Gear Ratios: 000, 004, 006, 009, 012, 015, 021, 027, 037, 044	4 Hole Flange Mounting on Gear Ratios: 000, 004, 006, 009, 012, 015, 021, 027, 037, 044	½" Square Drive Shaft on Gear Ratios: 000, 004, 006, 009, 012, 015, 021, 027, 037, 044
6 Hole Face Mounting on Gear Ratios: 063, 086, 119, 151, 188, 275, 374	Side Inlet and Exhaust Housing (for Reversible Models only)	¾" Square Drive Shaft on Gear Ratios: 063, 086, 119, 151, 188, 275, 374
½" Round Keyed Shaft on Gear Ratios: 000, 004, 006, 009, 012, 015, 021, 027, 037, 044	¾"—24 or ½"—20 Threaded Shaft on Gear Ratios: 000, 004, 006, 009, 012, 015, 021, 027, 037, 044	
¾" Round Keyed Shaft on Gear Ratios: 063, 086, 119, 151, 188, 275, 374		

SERIES M007 MULTI-VANE AIR MOTORS



SERIES M007 DIMENSIONS

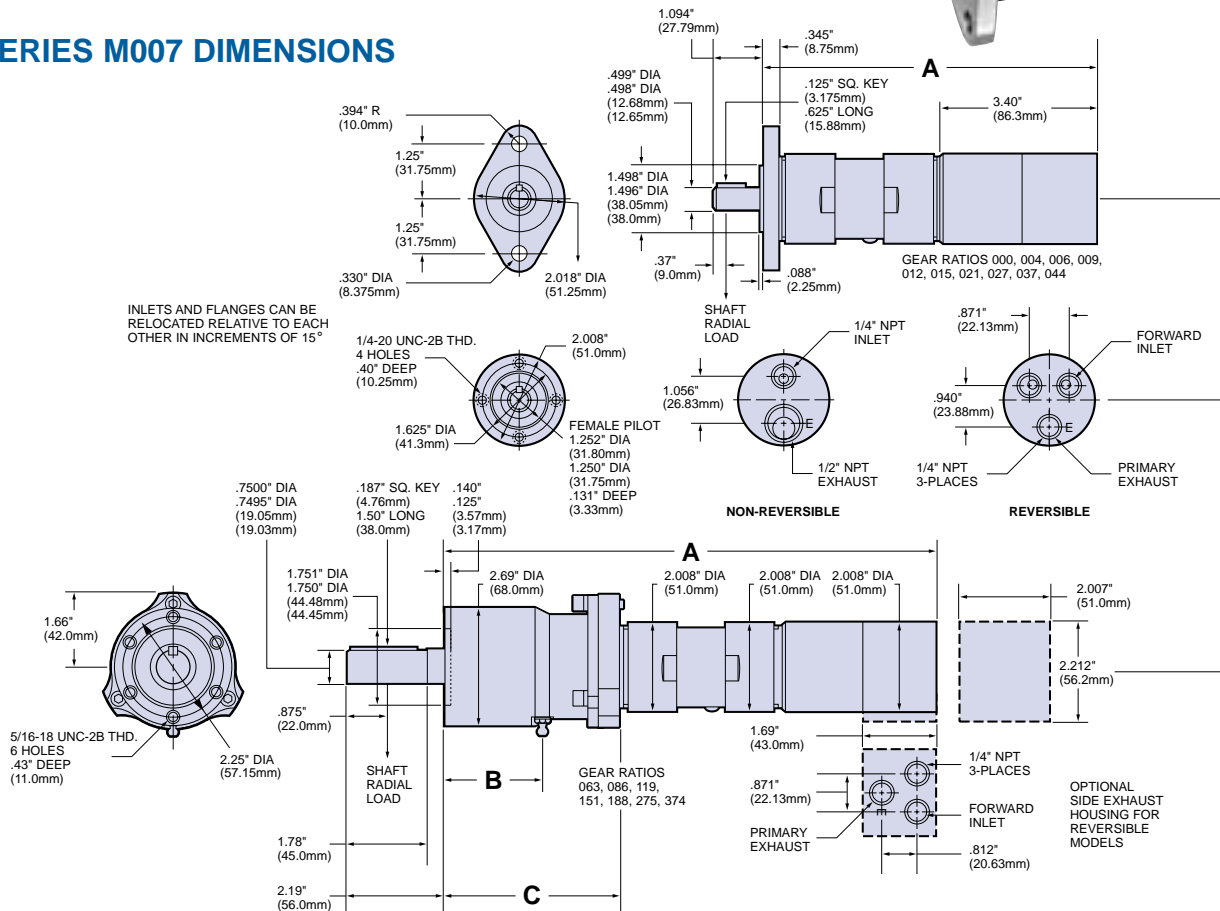

SERIES M007 MODEL NUMBER SYMBOLIZATION

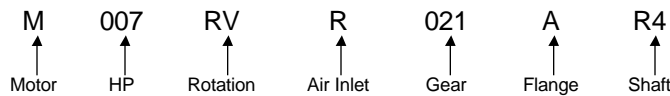

HP = Approximate horsepower range (.61 to .85)

Rotation = RV Reversible
 RH Non-Reversible, Right Hand from Rear of Motor (CCW facing shaft)
 LH Non-Reversible, Left Hand from Rear of Motor (CW facing shaft)

Air Inlet & Exhaust = R Rear, S Side (Side Inlet and Exhaust available on Reversible Models only)

Gear Ratio = 021 is 1 to 21, 027 is 1 to 27, etc.

Flange = A 2 Hole Flange, B 4 Hole Face Mounting (on 000, 004, 006, 009, 012, 015, 021, 027, 037, 044 gear ratios), B 6 Hole Face Mounting (on 063, 086, 119, 151, 188, 275, 374 gear ratios).

Shaft = R4 1/2" Round Keyed (on 000, 004, 006, 009, 012, 015, 021, 027, 037, 044 gear ratios).

R6 3/4" Round Keyed (on 063, 086, 119, 151, 188, 275, 374 gear ratios).

S4 1/2" Square Drive (on 000, 004, 006, 009, 012, 015, 021, 027, 037, 044 gear ratios).

Shaft Extension 1.31" (33.27mm)

S5 5/8" Square Drive (on 063, 086, 119, 151, 188, 275, 374 gear ratios).

Shaft Extension 1.25" (31.75mm)

T3 3/8"-24 UNF-2A Threaded (on 000, 004, 006, 009, 012, 015, 021, 027, 037, 044 gear ratios).

Shaft Extension .512" (13mm)

T4 1/2" 20 UNF-2A Threaded (on 000, 004, 006, 009, 012, 015, 021, 027, 037, 044 gear ratios).

Shaft Extension .512" (13mm)

DIMENSIONS

Gear Ratios (Refer to Model No.)	A		B		C	
	in.	mm	in.	mm	in.	mm
000, 004, 006, 009	7.362	187.0				
012, 015, 021, 027, 037, 044	8.133	206.56				
063, 086	9.343	237.3	.41	10	2.3	58.4
119, 188, 275, 374, 151	10.937	277.8	2.19	56	3.9	99.0



SERIES 1801 AND 1841 MULTI-VANE AIR MOTORS

Round Keyed Shaft • Square Shaft (Optional) • 1.1 to 1.4 hp
Geared Drive • Flange Mounted

SPECIFICATIONS

Model	Max. Power		Speed at Max. Power	Free Speed▲	Starting Torque		Stall Torque		Air Consumption at Max. Power		Weight	
	hp	kw	rpm	rpm	lb.-ft.	Nm	lb.-ft.	Nm	scfm	m ³ /m	lb.	kg
Non-Reversible Direction of rotation is counterclockwise when facing the shaft.												
1801N	1.40	1.04	918	1990	10.5	14.2	14	19.0	46	1.3	5%	2.44
1801P	1.35	1.01	500	1050	17.2	23.3	23	31.2	46	1.3	5%	2.61
1801Q	1.35	1.01	300	650	30.0	40.7	40	54.2	46	1.3	5%	2.61
1801U	1.35	1.01	205	435	41.0	55.6	55	74.6	46	1.3	5%	2.61
1801W	1.35	1.01	175	370	52.0	70.5	70	94.9	46	1.3	5%	2.61
Reversible												
1841N	1.2	.89	800	1700	9.3	12.6	12.5	17.0	43	1.22	5%	2.50
1841P	1.1	.82	430	900	15.0	20.3	20.0	27.1	43	1.22	5%	2.67
1841Q	1.1	.82	260	550	27.0	36.6	36.0	48.8	43	1.22	5%	2.67
1841U	1.1	.82	175	380	37.0	50.2	50.0	67.8	43	1.22	5%	2.67
1841W	1.1	.82	150	320	45.0	61.0	60.0	81.4	43	1.22	5%	2.67

▲ ALL models must be operated with sufficient load to prevent speed from exceeding maximum allowable speed shown on performance curve. Performance figures are at 90 psig (620 kPa) air pressure.

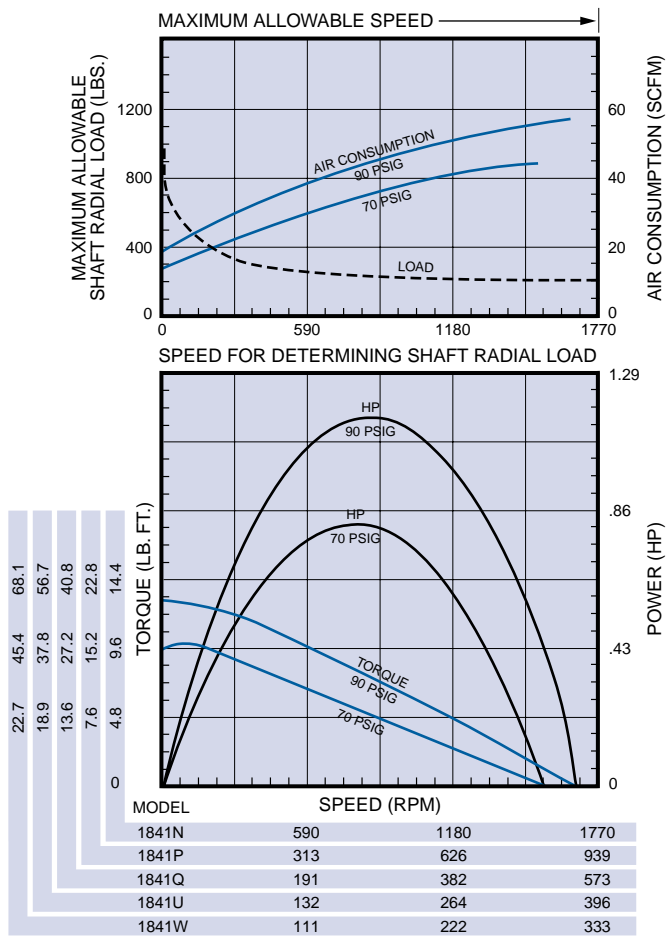
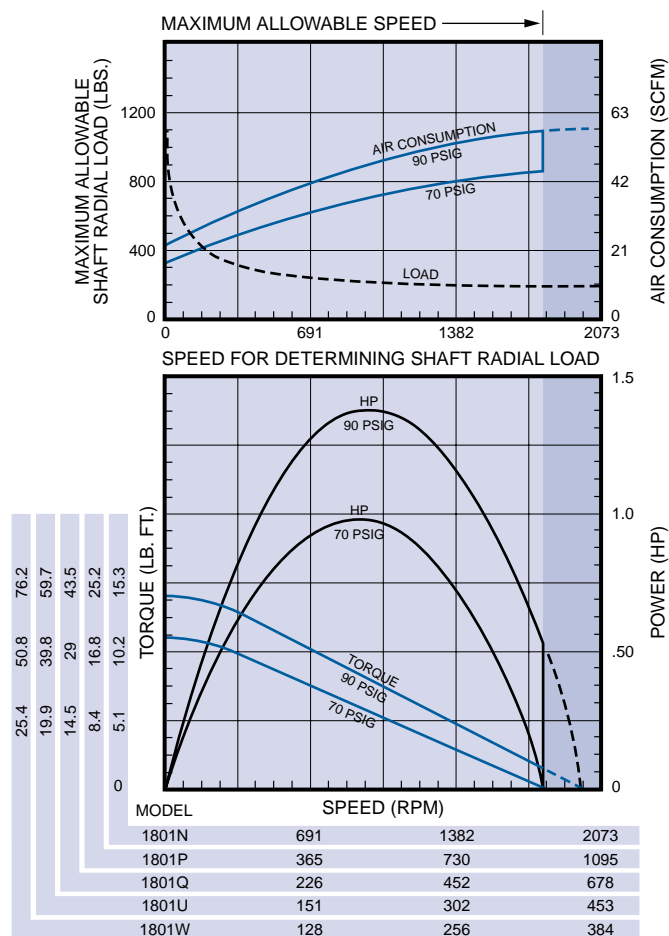

SERIES 1801 AND 1841 MULTI-VANE AIR MOTORS

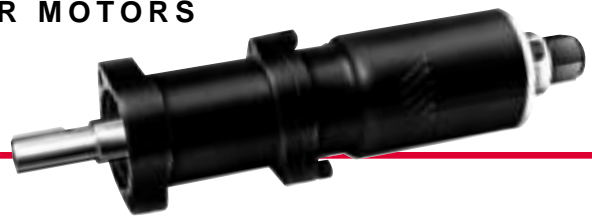

SERIES 1801 AND 1841 DIMENSIONS

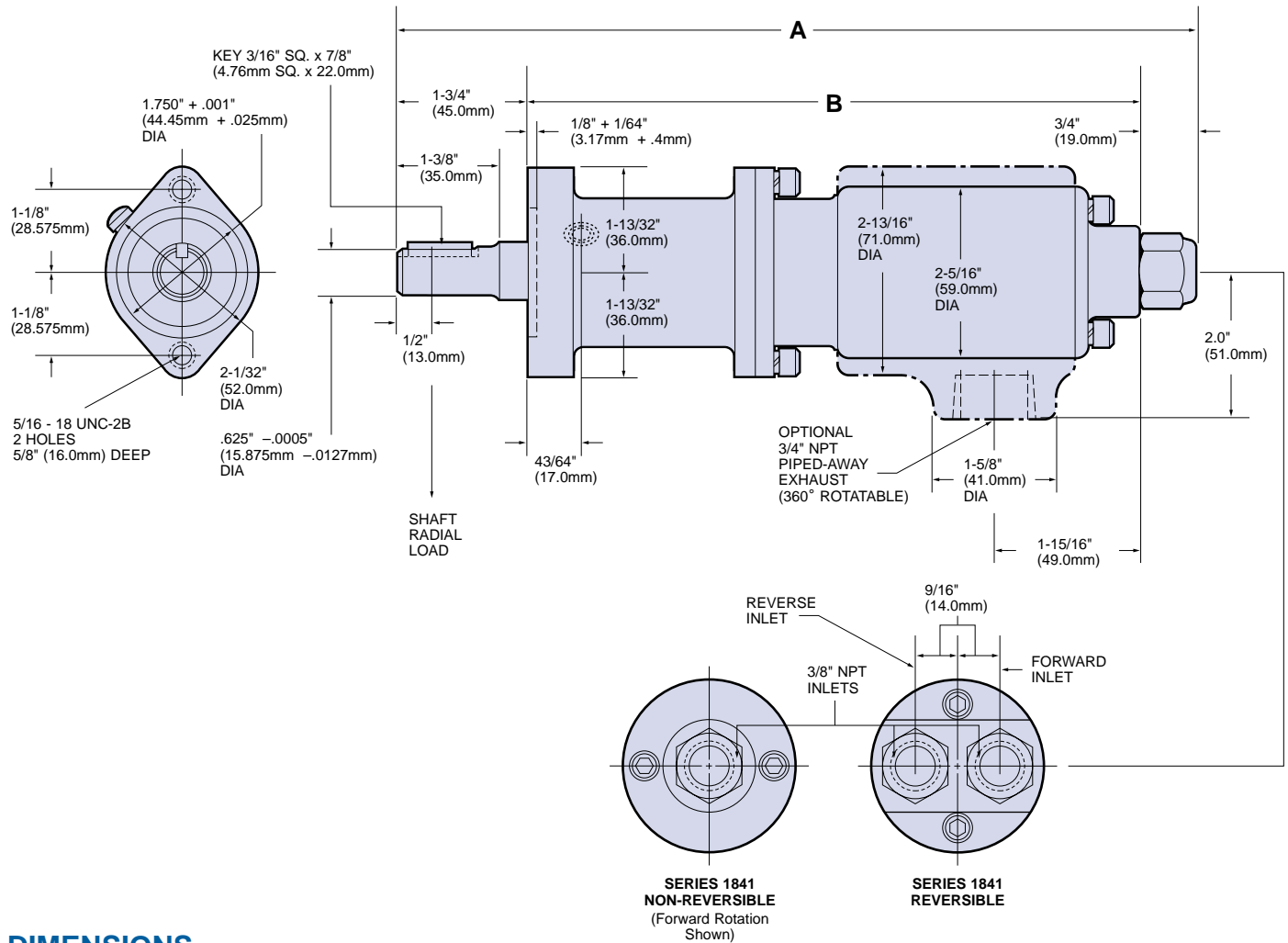

DIMENSIONS

Models	A		B	
	in.	mm	in.	mm
1801N, 1841N	9 ⁷ / ₁₆	240	6 ¹⁵ / ₁₆	176
1801P, 1801Q, 1801U, 1801W, 1841P, 1841Q, 1841U, 1841W	10 ¹³ / ₁₆	275	8 ⁵ / ₁₆	211

EQUIPMENT OPTIONS

Furnished with Cataloged Models	Optional at Extra Price
2 Hole Face Mounting	R1801-A123 Exhaust Deflector Assembly with 3/8" Pipe Tap
	*1/2" Square Drive Shaft on Gear Ratios: P, Q, U Shaft Extension 1.19" (30.23mm)
	*5/8" Square Drive Shaft on Gear Ratios: W Shaft Extension 1.19" (30.23mm)

*To order Motor with Square Drive Shaft, add the suffix "2" to the Model Number. Example: 1841Q2.

SERIES 3800 AND 3840 MULTI-VANE AIR MOTORS

Round Keyed Shaft • Square Shaft (Optional) • 1.35 to 1.55 hp
Geared Drive • Face Mounted

SPECIFICATIONS

Model	Max. Power		Speed at Max. Power	Free Speed▲	Starting Torque		Stall Torque		Air Consumption at Max. Power		Weight	
	hp	kw	rpm	rpm	lb.-ft.	Nm	lb.-ft.	Nm	scfm	m ³ /m	lb.	kg
Non-Reversible Direction of rotation is counterclockwise when facing the shaft.												
3800M	1.55	1.16	520	1100	24	32.5	33	44.8	48	1.36	7½	3.23
3800P	1.45	1.08	285	600	42	57	56.5	76.6	48	1.36	8½	3.86
3800Q	1.45	1.08	180	375	62	84	83.5	113	48	1.36	8½	3.86
3800R	1.45	1.08	150	320	72	98	96	130	48	1.36	8½	3.86
3800S	1.45	1.08	120	255	88	119	118	160	48	1.36	8½	3.86
3800U	1.45	1.08	105	220	105	142	140	189	48	1.36	8½	3.86
Reversible												
3840M	1.40	1.04	390	825	23	31.2	31.5	42.7	44	1.25	7½	3.35
3840P	1.35	1.01	215	440	40	54.2	53.5	72.6	44	1.25	8½	3.97
3840Q	1.35	1.01	130	280	60	81.4	80	106	44	1.25	8½	3.97
3840R	1.35	1.01	122	238	69	93	92	125	44	1.25	8½	3.97
3840S	1.35	1.01	100	190	86	116	115	156	44	1.25	8½	3.97
3840U	1.35	1.01	83	162	100	135	134	181	44	1.25	8½	3.97

▲ ALL models must be operated with sufficient load to prevent speed from exceeding maximum allowable speed shown on performance curve. Performance figures are at 90 psig (620 kPa) air pressure.

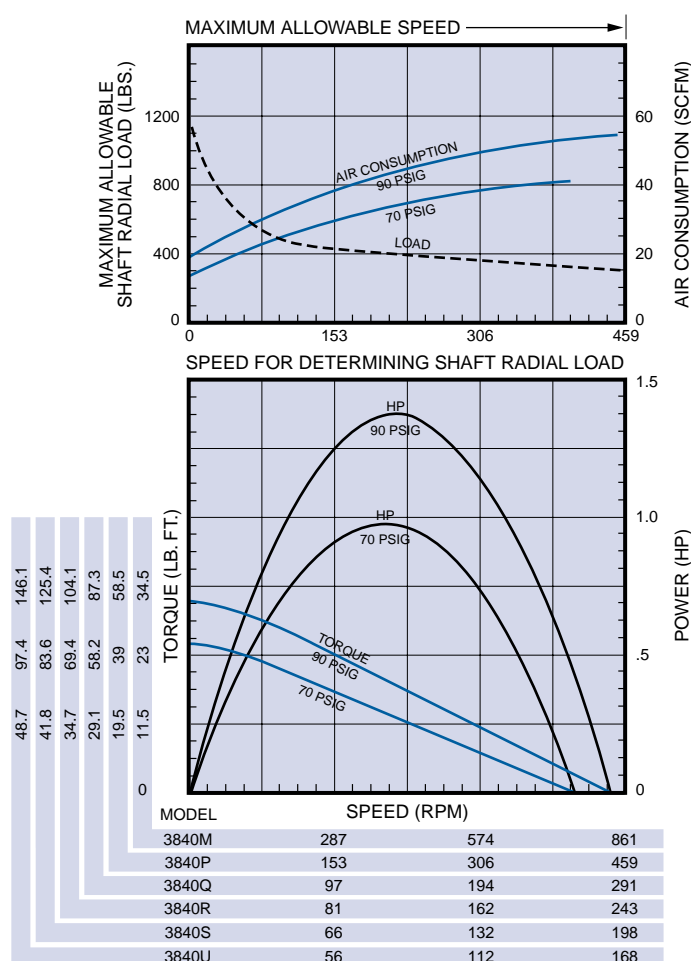
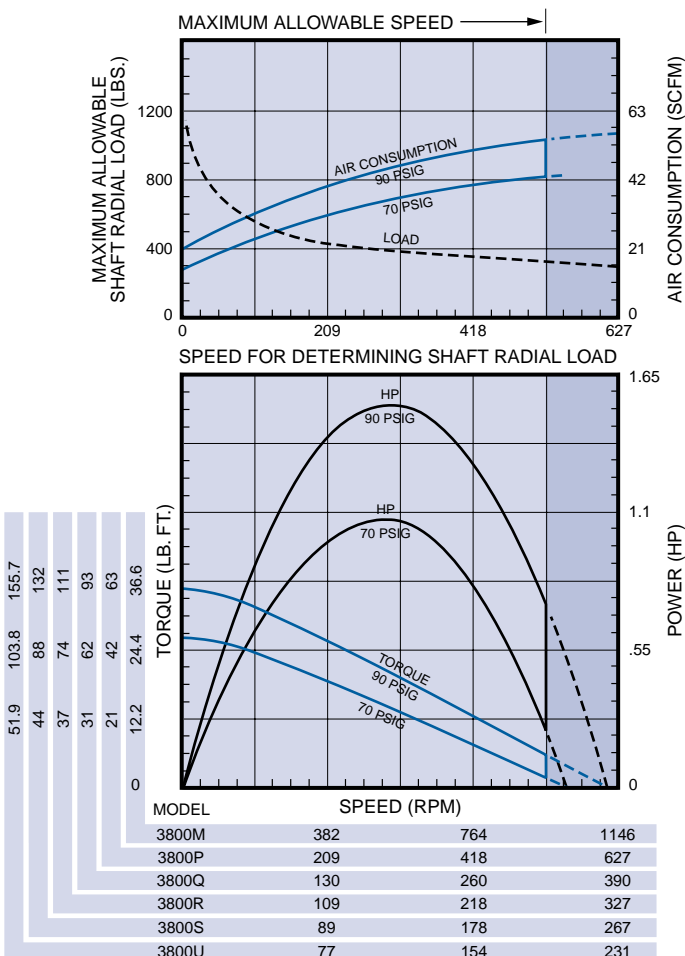

SERIES 3800 AND 3840 MULTI-VANE AIR MOTORS



SERIES 3800 AND 3840 DIMENSIONS

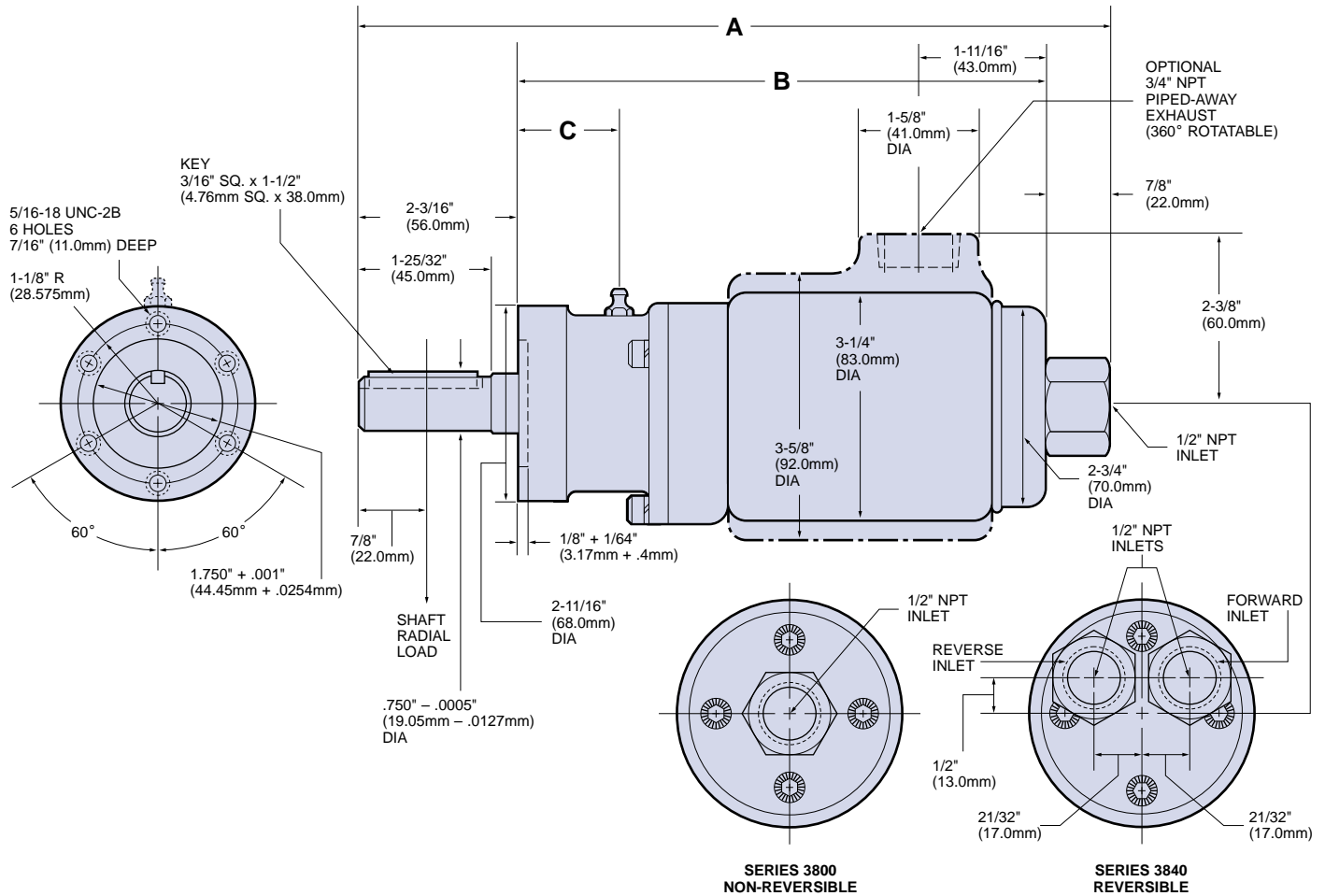

DIMENSIONS

MODELS	A		B		C	
	in.	mm	in.	mm	in.	mm
3800M, 3840M	10 ¹ / ₁₆	256	7	178	1 ¹ / ₁₆	27
3800P, 3800Q, 3800R, 3800S, 3800U	11 ³ / ₁₆	299	8 ¹ / ₁₆	221	2 ¹ / ₁₆	56
3840P, 3840Q, 3840R, 3840S, 3840U						

EQUIPMENT OPTIONS

Furnished with Cataloged Models	Optional at Extra Price
6 Hole Face Mounting	R3800-A123 Exhaust Deflector Assembly with 3/4" Pipe Tap
	*5/8" Square Drive Shaft Shaft Extension 1.25" (31.75mm)

*To order Motor with Square Drive Shaft, add the suffix "2" to the Model Number. Example: 3840Q2.

SERIES 4800 AND 4840 MULTI-VANE AIR MOTORS

Round Keyed Shaft • Square Shaft (Optional) • 3 to 3.8 hp
Geared Drive • Face Mounted

SPECIFICATIONS

Model	Max. Power		Speed at Max. Power	Free Speed▲	Starting Torque		Stall Torque		Air Consumption at Max. Power		Weight	
	hp	kw	rpm	rpm	lb.-ft.	Nm	lb.-ft.	Nm	scfm	m ³ /m	lb.	kg
Non-Reversible Direction of rotation is counterclockwise when facing the shaft.												
4800D	3.8	2.83	5250	9850	5.8	7.8	7.7	10.4	98	2.77	15¼	6.92
4800K	3.7	2.76	821	1538	35.3	47.8	47	63.7	95	2.69	15¼	6.92
4800M	3.7	2.76	560	1050	51	69.2	69	93.6	95	2.69	15¼	6.92
4800N	3.7	2.76	387	726	75	102	100	136	95	2.69	15¼	6.92
4800P	3.5	2.61	260	510	98	133	131	178	95	2.69	19¾	8.96
4800Q	3.5	2.61	194	375	129	175	173	235	95	2.69	19¾	8.96
4800S	3.5	2.61	146	275	178	241	238	323	95	2.69	19¾	8.96
4800U	3.5	2.61	97	185	265	359	354	480	95	2.69	19¾	8.96
Reversible												
4840D	3.3	2.46	4550	9100	5.2	7.0	6.9	9.4	95	2.69	15¼	6.92
4840K	3.2	2.39	711	1429	32	43.4	42.7	57.9	95	2.69	15¼	6.92
4840M	3.2	2.39	485	975	47.3	64.0	63.0	85.4	95	2.69	15½	6.97
4840N	3.2	2.39	336	675	67.7	91.7	90.2	122	95	2.69	15½	6.92
4840P	3	2.24	228	475	93	126	125	170	95	2.69	20½	9.13
4840Q	3	2.24	167	350	123	167	165	224	95	2.69	20½	9.13
4840S	3	2.24	125	255	161	218	215	292	95	2.69	20½	9.13
4840U	3	2.24	83	170	225	305	300	407	95	2.69	20½	9.13

▲ ALL models must be operated with sufficient load to prevent speed from exceeding maximum allowable speed shown on performance curve. Performance figures are at 90 psig (620 kPa) air pressure.

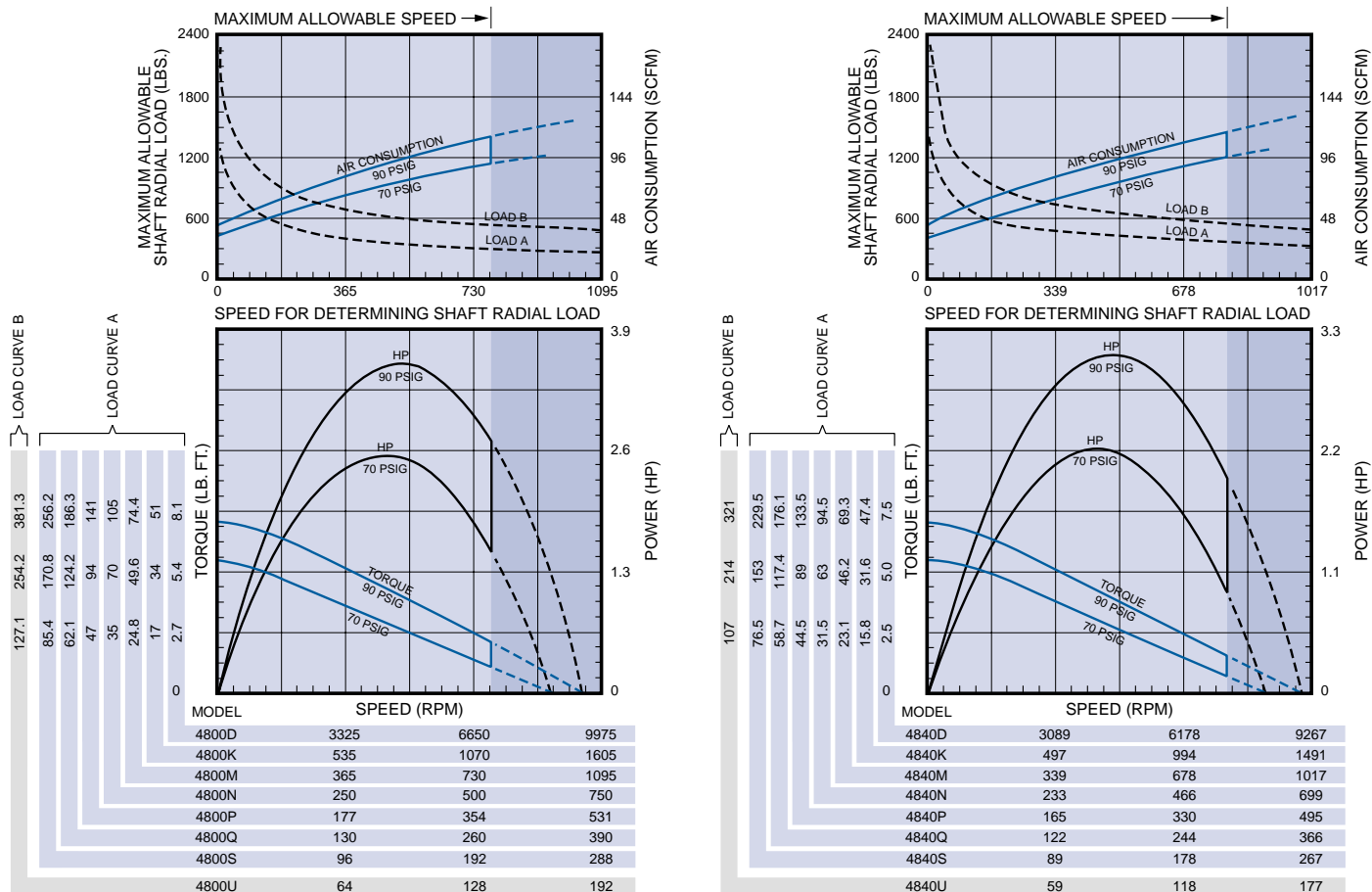

SERIES 4800 AND 4840 MULTI-VANE AIR MOTORS

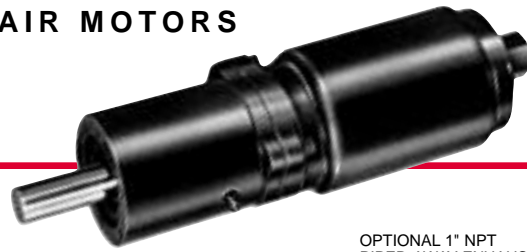

SERIES 4800 AND 4840 DIMENSIONS

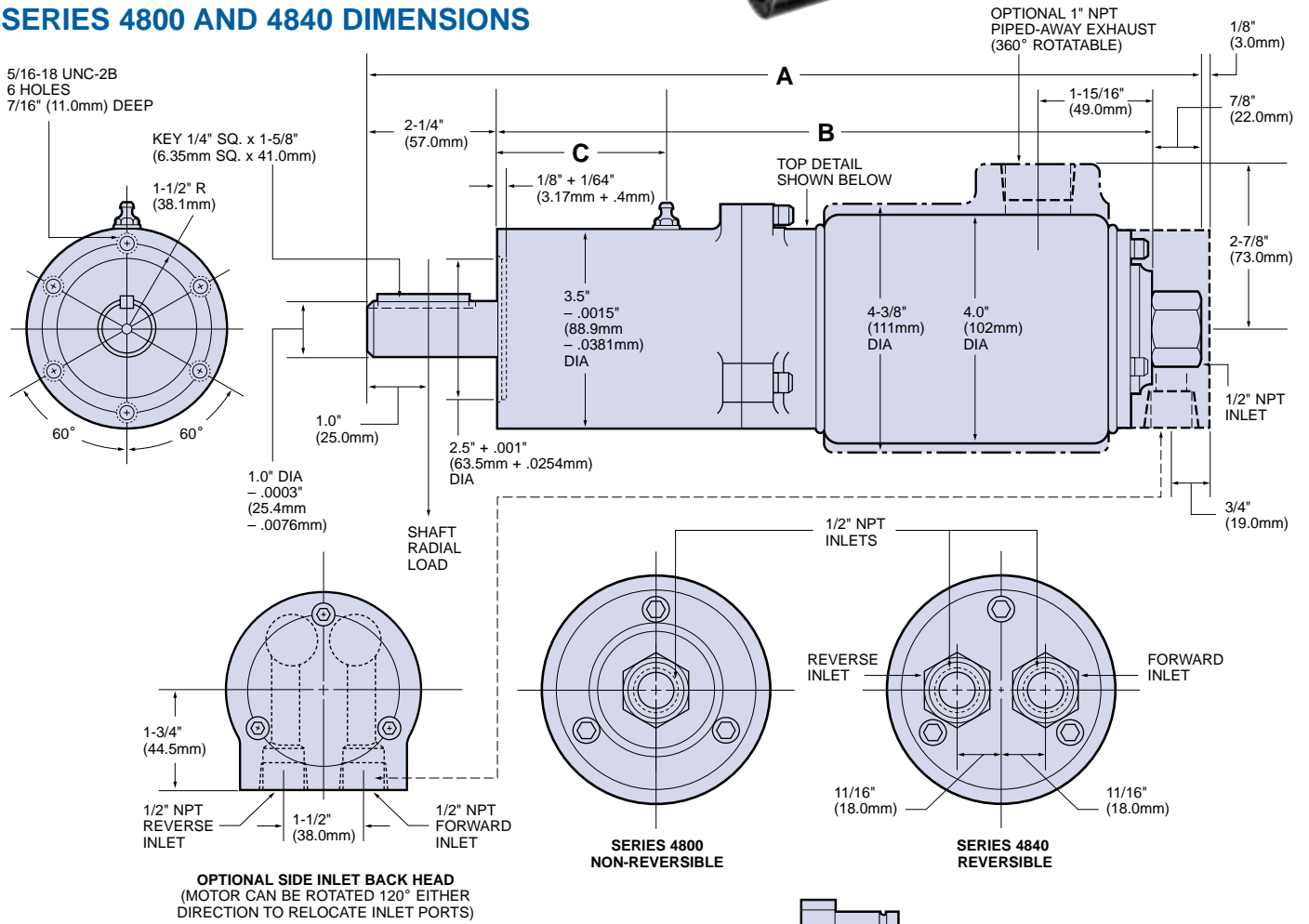

DIMENSIONS

MODELS	A		B		C	
	in.	mm	in.	mm	in.	mm
4800D, 4800K, 4800M, 4800N 4840D, 4840K, 4840M, 4840N	12 1/8	308	9	229	2 9/32	23
4800P, 4800Q, 4800S, 4800U 4840P, 4840Q, 4840S, 4840U	14 1/2	368	11 3/8	289	2 7/8	73

EQUIPMENT OPTIONS

Furnished with Cataloged Models	Optional at Extra Price
6 Hole Face Mounting	R4800-A123 Exhaust Deflector Assembly with 1" Pipe Tap ** R4901-102 Side Inlet Backhead Requires (3) 518-104 Screws
	* 5/8" Square Drive Shaft on Gear Ratio: M Shaft Extension 1.38" (35.5mm) * 3/4" Square Drive Shaft on Gear Ratios: P, Q, S, U Shaft Extension 1.47" (37.44mm)

*To order Motor with Square Drive Shaft, add the suffix "2" to the Model Number. Example: 4840Q2.

**Contact I-R for Model Number with these options.

SERIES 17RA, 17RB, 34RA, AND 34RB MULTI-VANE AIR MOTORS

Round Keyed Shaft • 2.2 to 4.1 hp • Geared Drive • Flange or Base Mounted

SPECIFICATIONS

Model	Max. Power		Speed at Max. Power	Free Speed▲	Starting Torque		Stall Torque		Air Consumption at Max. Power		Weight	
	hp	kw	rpm	rpm	lb.-ft.	Nm	lb.-ft.	Nm	scfm	m ³ /m	lb.	kg
Reversible												
17RA005	2.3	1.72	562	1110	24	32.5	37	50.2	103	2.92	40	18.1
17RA008	2.3	1.72	383	760	35	47.5	54.5	73.9	103	2.92	40	18.1
17RA011	2.3	1.72	254	505	53	71.9	82	111	103	2.92	40	18.1
17RA014	2.3	1.72	201	400	67	91	104	141	103	2.92	40	18.1
17RA017	2.3	1.72	169	335	80	109	124	168	103	2.92	40	18.1
17RA022	2.3	1.72	129	255	105	142	163	221	103	2.92	40	18.1
17RB029	2.2	1.64	97	187	120	163	201	273	100	2.83	72	32.7
17RB036	2.2	1.64	79	152	148	201	248	336	100	2.83	72	32.7
17RB045	2.2	1.64	62	121	187	254	312	423	100	2.83	72	32.7
17RB078	2.2	1.64	36	69	327	443	545	739	100	2.83	72	32.7
34RA005	4.1	3.06	560	1080	41	60	69	93.6	183	5.18	43	19.5
34RA008	4.1	3.06	385	740	65	88	101	137	183	5.18	43	19.5
34RA011	4.1	3.06	255	490	98	133	152	206	183	5.18	43	19.5
34RA014	4.1	3.06	201	390	124	168	192	260	183	5.18	43	19.5
34RA017	4.1	3.06	168	325	148	201	229	311	183	5.18	43	19.5
34RA022	4.1	3.06	128	245	195	264	301	408	183	5.18	43	19.5
34RB029	4	2.98	99	187	224	304	374	507	180	5.1	75	34
34RB036	4	2.98	80	152	277	376	462	627	180	5.1	75	34
34RB045	4	2.98	63	121	348	472	581	788	180	5.1	75	34
34RB078	4	2.98	36	69	606	822	1010	1370	180	5.1	75	34

▲ ALL models must be operated with sufficient load to prevent speed from exceeding maximum allowable speed shown on performance curve. Performance figures are at 90 psig (620 kPa) air pressure.

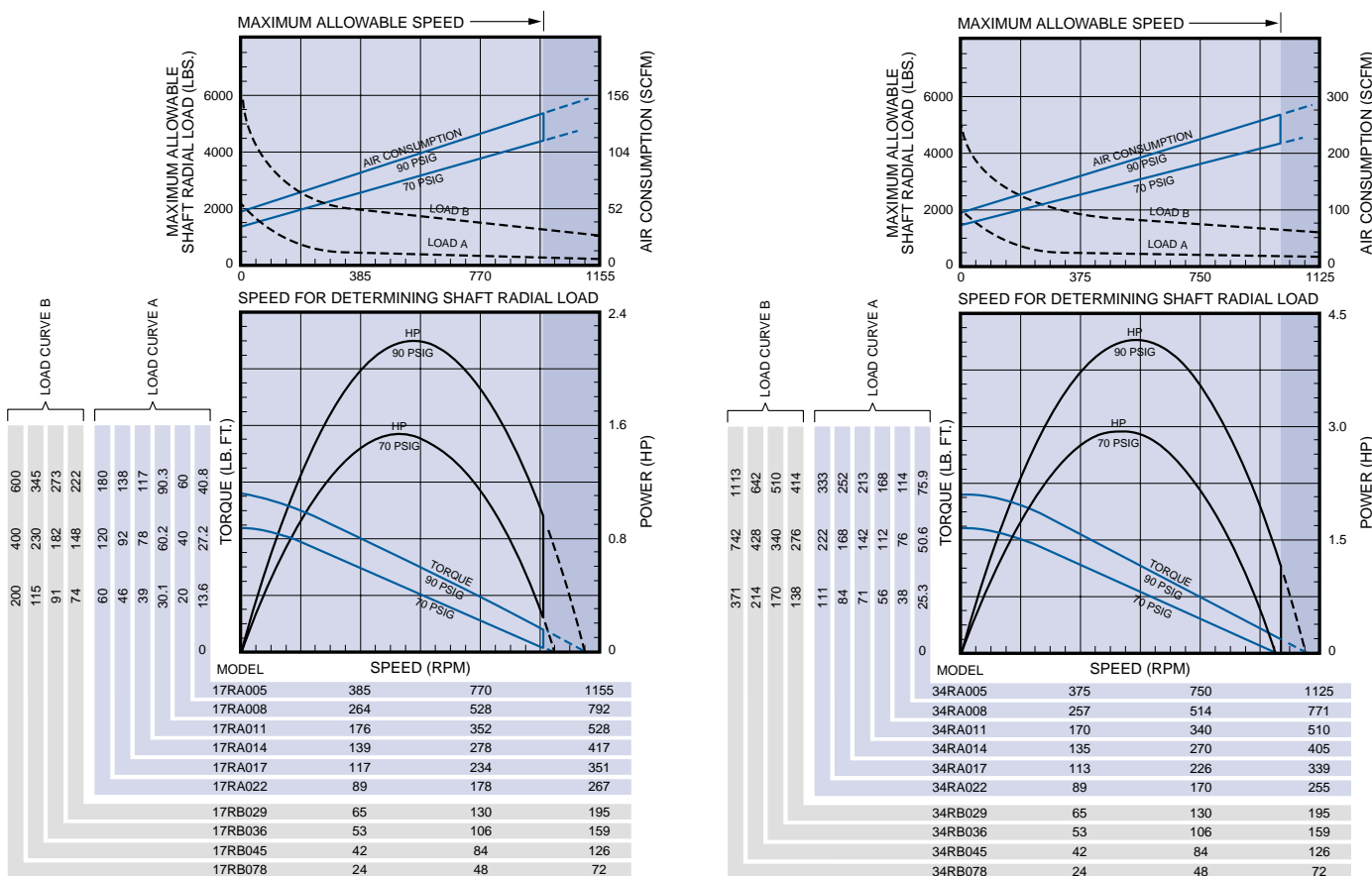

SERIES 17RA, 17RB, 34RA, AND 34RB MULTI-VANE AIR MOTORS

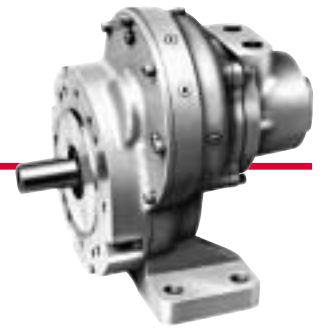

SERIES 17RA, 17RB, 34RA, 34RB DIMENSIONS

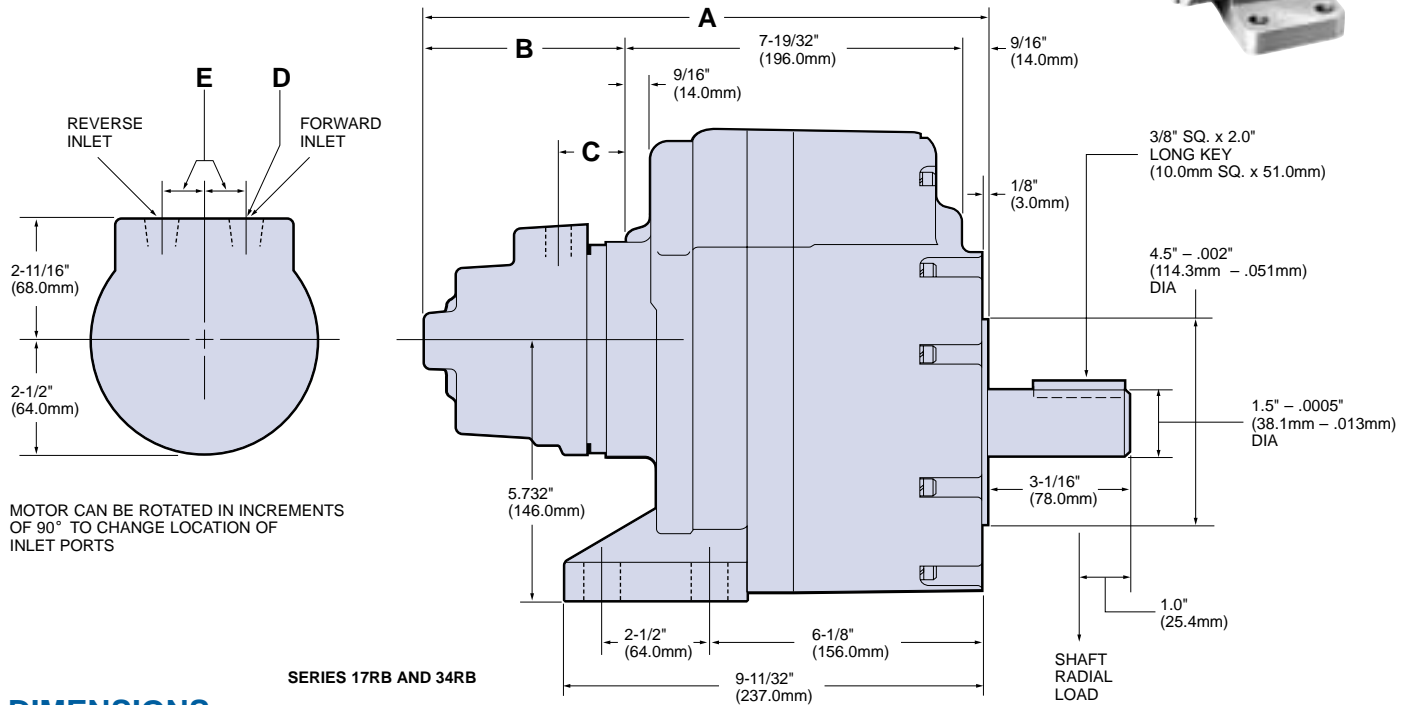

DIMENSIONS

SERIES	A		B		C		D	E	
	in.	mm	in.	mm	in.	mm		NPT	in.
17RB	13 ¹ / ₁₆	332	4 ²⁹ / ₃₂	125	2 ³ / ₁₆	56	3/8"	7/8	22
34RB	14 ¹³ / ₁₆	376	6 ² / ₃₂	169	2 ⁷ / ₃₂	58	1/2"	1 ¹ / ₁₆	30

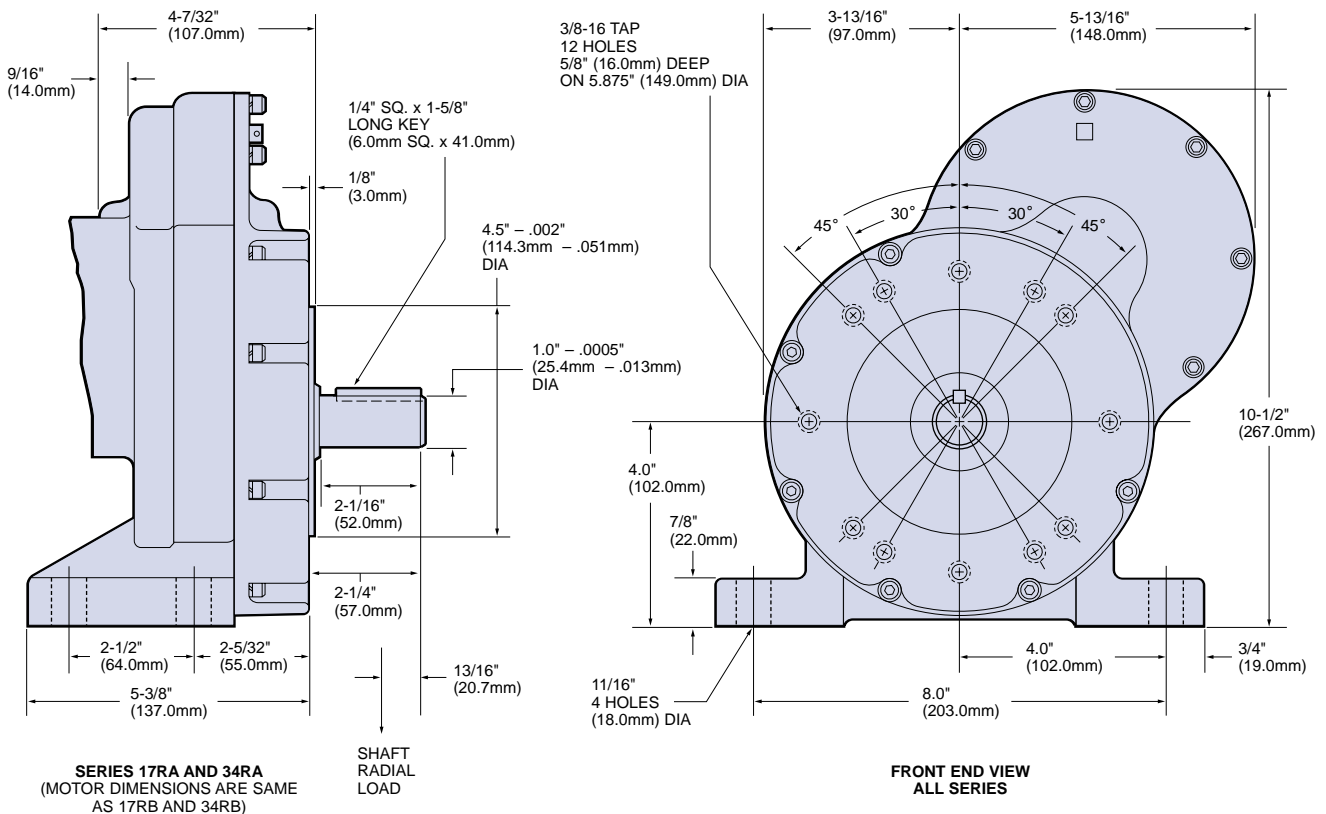

SERIES 48RA AND 48RB MULTI-VANE AIR MOTORS

Round Keyed Shaft • 3 to 3.1 hp • Geared Drive • Flange or Base Mounted

SPECIFICATIONS

Model	Max. Power		Speed at Max. Power	Free Speed▲	Starting Torque		Stall Torque		Air Consumption at Max. Power		Weight	
	hp	kw	rpm	rpm	lb.-ft.	Nm	lb.-ft.	Nm	scfm	m ³ /m	lb.	kg
Reversible												
48RA005	3.1	2.31	930	1690	26	35.3	35	47.5	95	2.69	44	20
48RA008	3.1	2.31	638	1160	38	51.5	51.5	69.8	95	2.69	44	20
48RA011	3.1	2.31	423	772	57	77.3	77.5	105	95	2.69	44	20
48RA014	3.1	2.31	332	612	72	97.6	98	133	95	2.69	44	20
48RA017	3.1	2.31	278	511	86	117	117	159	95	2.69	44	20
48RA022	3.1	2.31	213	390	113	153	154	209	95	2.69	44	20
48RB029	3	2.24	162	292	135	183	189	256	90	2.55	75	34
48RB036	3	2.24	131	236	167	227	234	317	90	2.55	75	34
48RB045	3	2.24	105	188	209	283	295	400	90	2.55	75	34
48RB078	3	2.24	60	108	364	494	513	696	90	2.55	75	34

▲ ALL models must be operated with sufficient load to prevent speed from exceeding maximum allowable speed shown on performance curve. Performance figures are at 90 psig (620 kPa) air pressure.

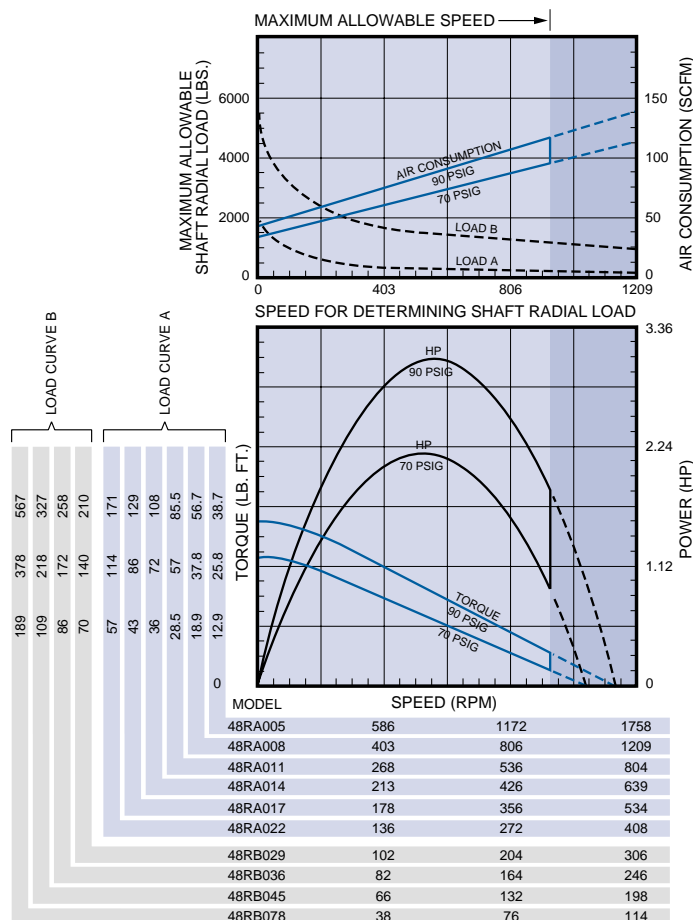

EQUIPMENT OPTIONS

Furnished with Cataloged Models	Optional at No Extra Price
Side Inlet Backhead	R4840-102 Rear Inlet Backhead

SERIES 48RA AND 48RB MULTI-VANE AIR MOTORS

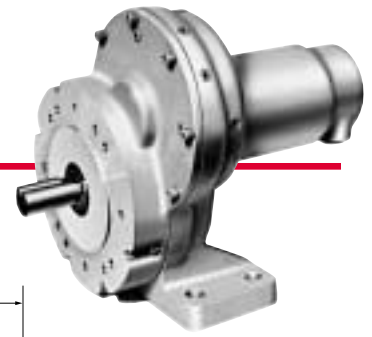

SERIES 48RA AND 48RB DIMENSIONS

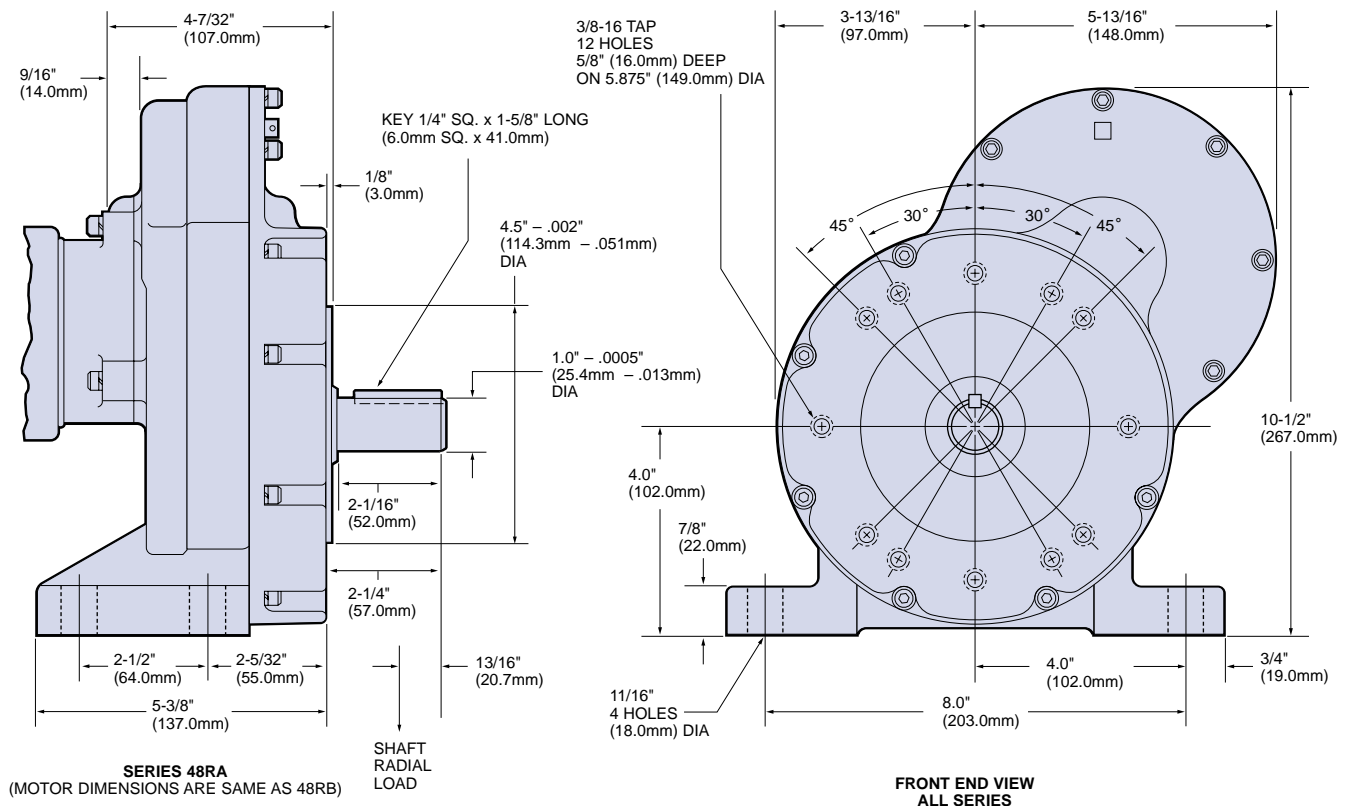
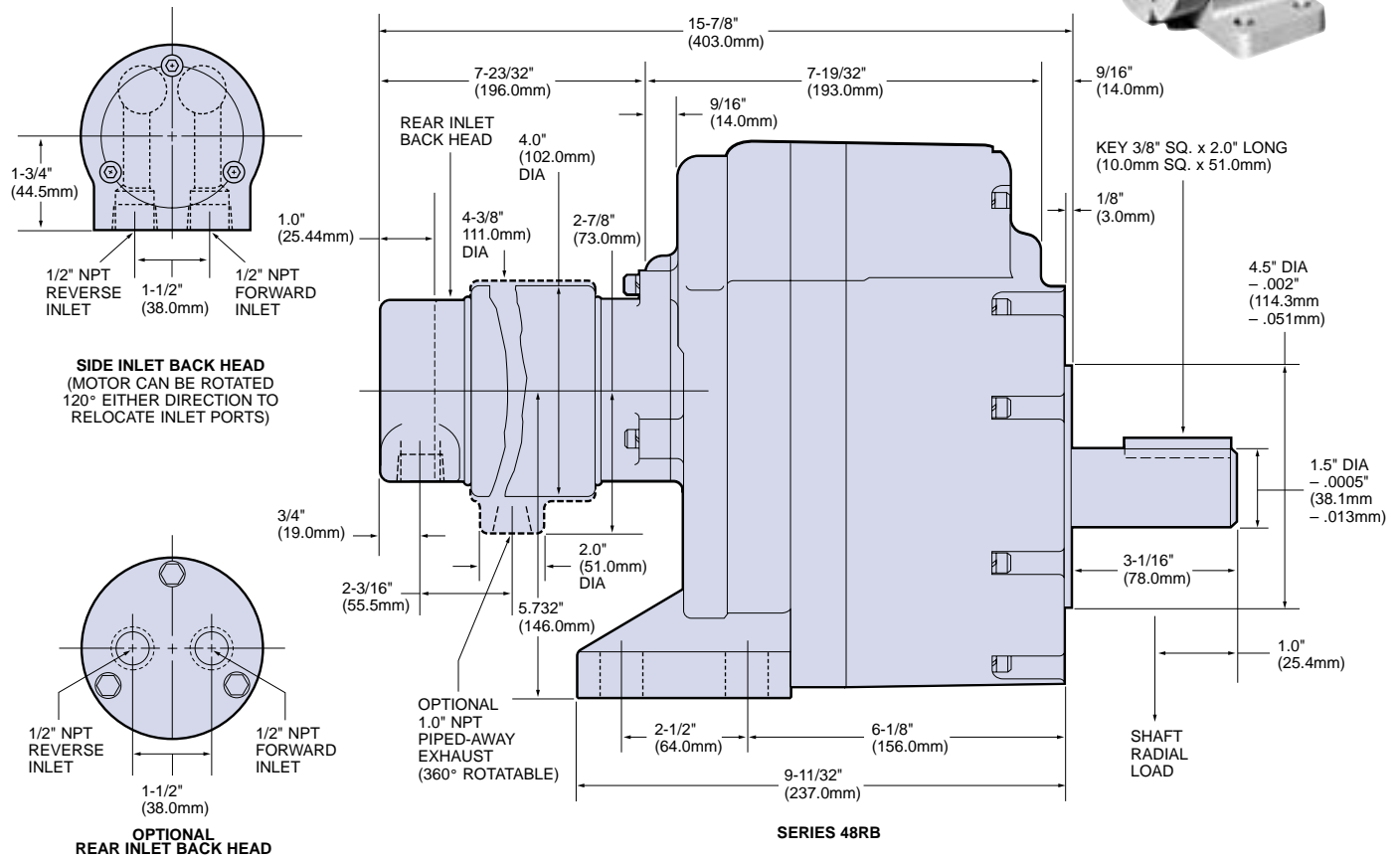

SERIES 92RA AND 92RB MULTI-VANE AIR MOTORS

Round Keyed Shaft • 7.9 to 8.15 hp • Geared Drive • Flange or Base Mounted

SPECIFICATIONS

Model	Max. Power		Speed at Max. Power	Free Speed▲	Starting Torque		Stall Torque		Air Consumption at Max. Power		Weight	
	hp	kw	rpm	rpm	lb.-ft.	Nm	lb.-ft.	Nm	scfm	m ³ /m	lb.	kg
Reversible												
92RA005	8.15	6.08	910	1390	56	75.9	75	102	230	6.51	46	20.9
92RA008	8.15	6.08	620	1296	80	109	109	148	230	6.51	46	20.9
92RA011	8.15	6.08	415	852	120	163	164.5	223	230	6.51	46	20.9
92RA014	8.15	6.08	327	682	152	206	208	282	230	6.51	46	20.9
92RA017	8.15	6.08	274	571	180	244	248	336	230	6.51	46	20.9
92RA022	8.15	6.08	209	435	235	319	326	442	230	6.51	46	20.9
92RB029	7.9	5.89	160	327	280	380	402	545	225	6.37	78	35.4
92RB036	7.9	5.89	130	264	345	468	497	674	225	6.37	78	35.4
92RB045	7.9	5.89	103	210	440	597	626	849	225	6.37	78	35.4
92RB078	7.9	5.89	59	120	770	1044	1090	1478	225	6.37	78	35.4

▲ ALL models must be operated with sufficient load to prevent speed from exceeding maximum allowable speed shown on performance curve. Performance figures are at 90 psig (620 kPa) air pressure.

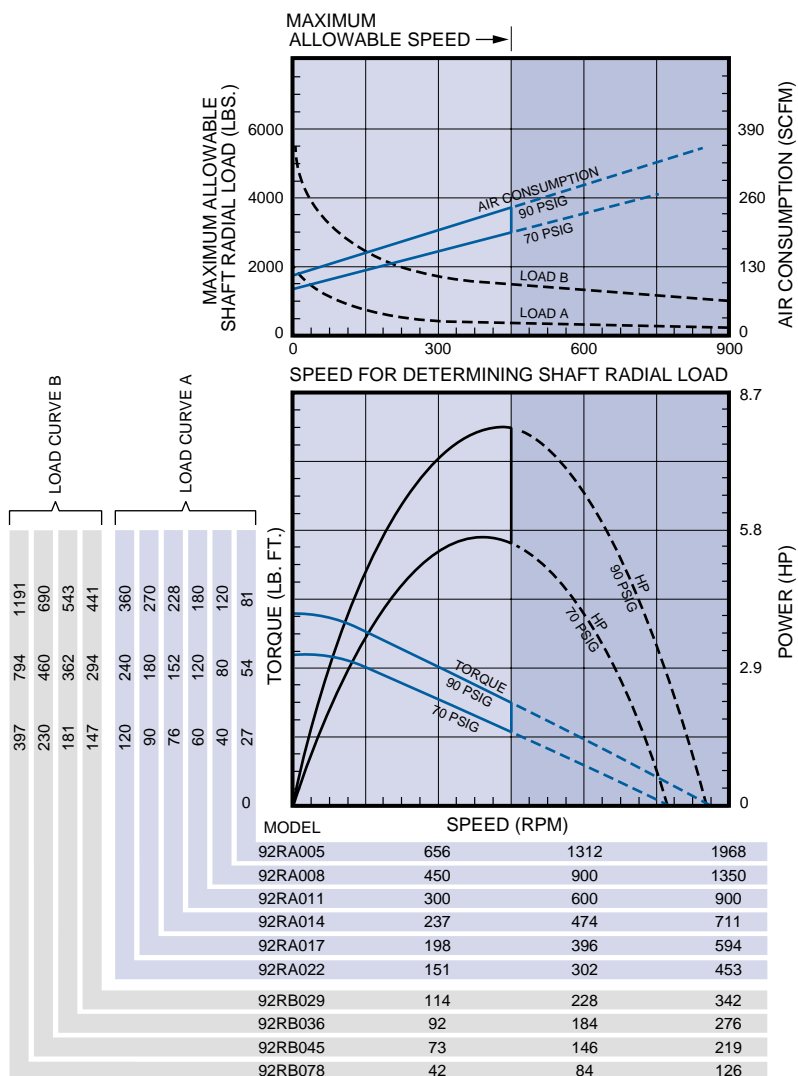

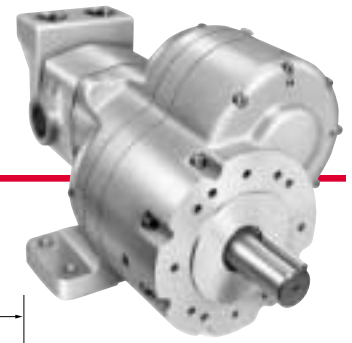

SERIES 92RA AND 92RB DIMENSIONS

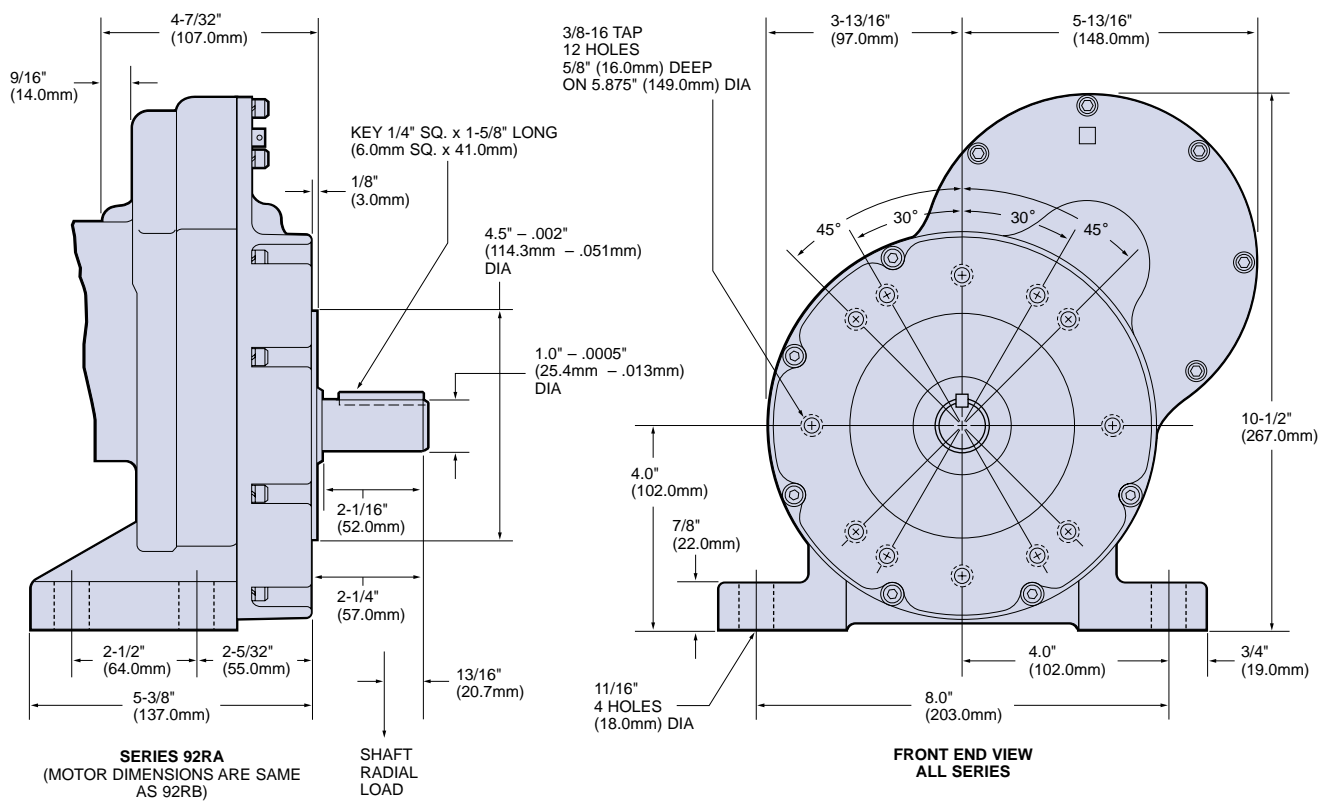
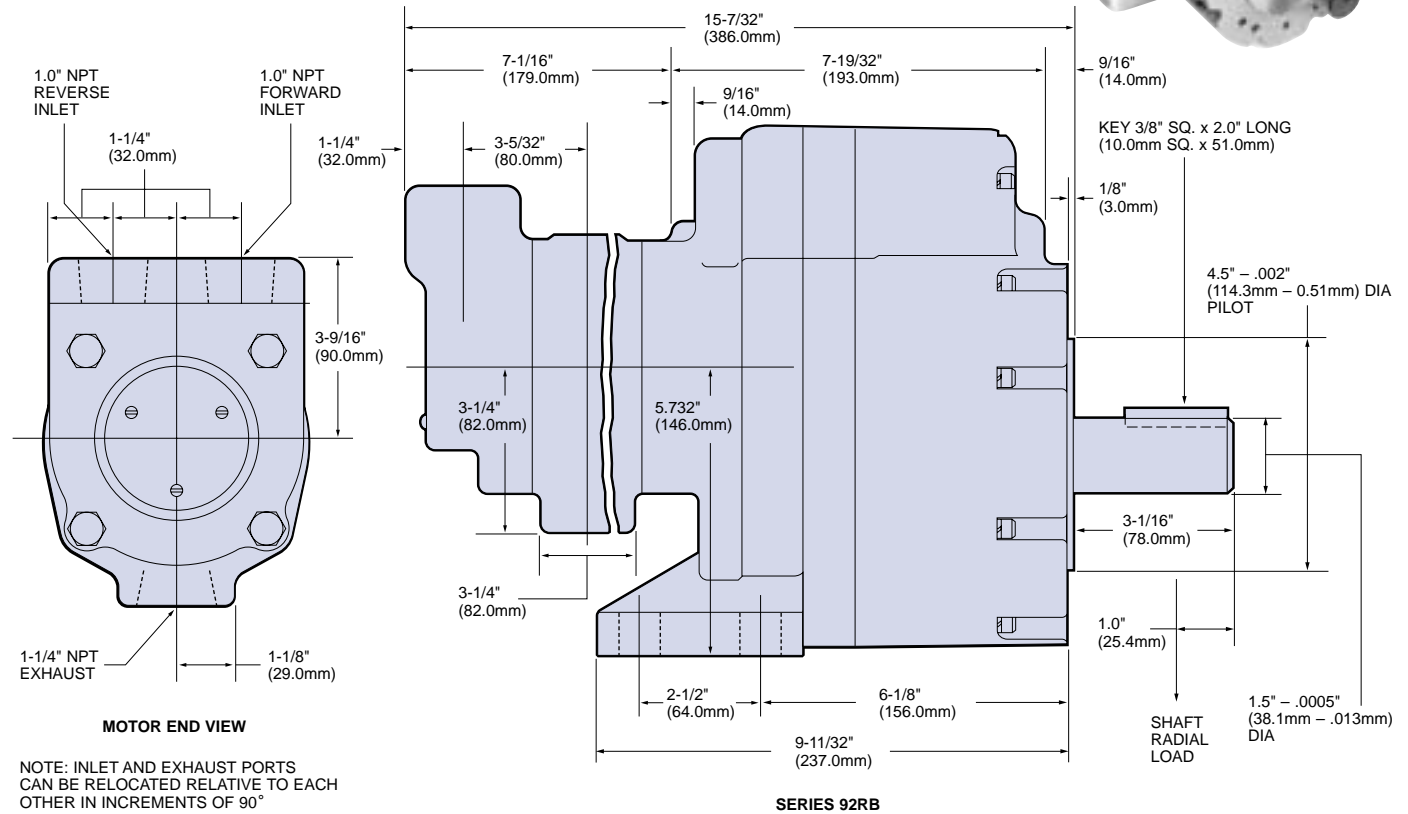

MODEL 22N51-W/RC MULTI-VANE AIR MOTORS

Round Keyed Shaft • 1.75 hp • Geared Drive,
Governed • Base Mounted

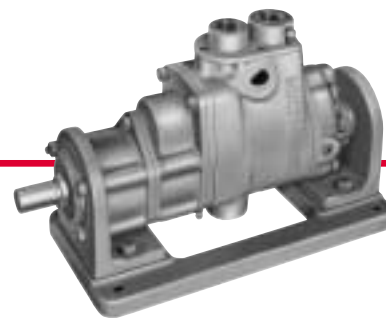

SPECIFICATIONS

Model	Max. Power		Speed at Max. Power	Free Speed	Starting Torque		Stall Torque		Air Consumption at Max. Power		Weight	
	hp	kw	rpm		rpm	lb.-ft.	Nm	lb.-ft.	Nm	scfm	m ³ /m	lb.
Reversible												
22N51-W/RC	1.75	1.31	208	280	49	66.4	66	89.5	55	1.6	21	9.5

Performance figures are at 90 psig (620 kPa) air pressure.

MODEL 22N51-W/RC DIMENSIONS

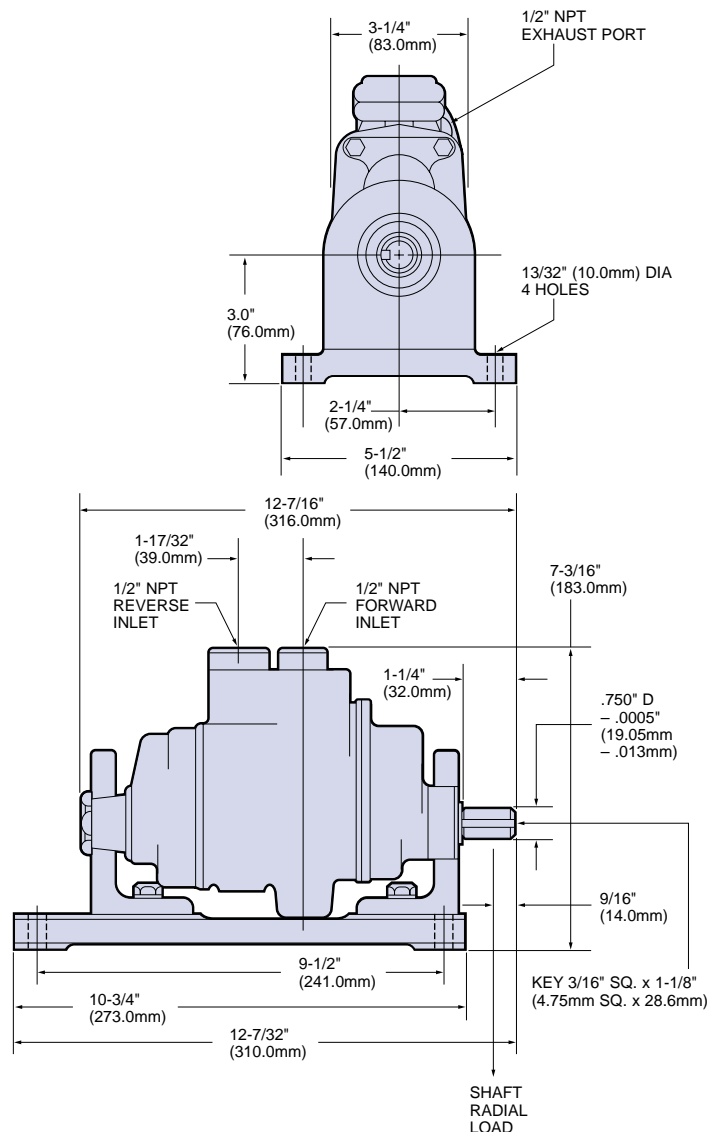
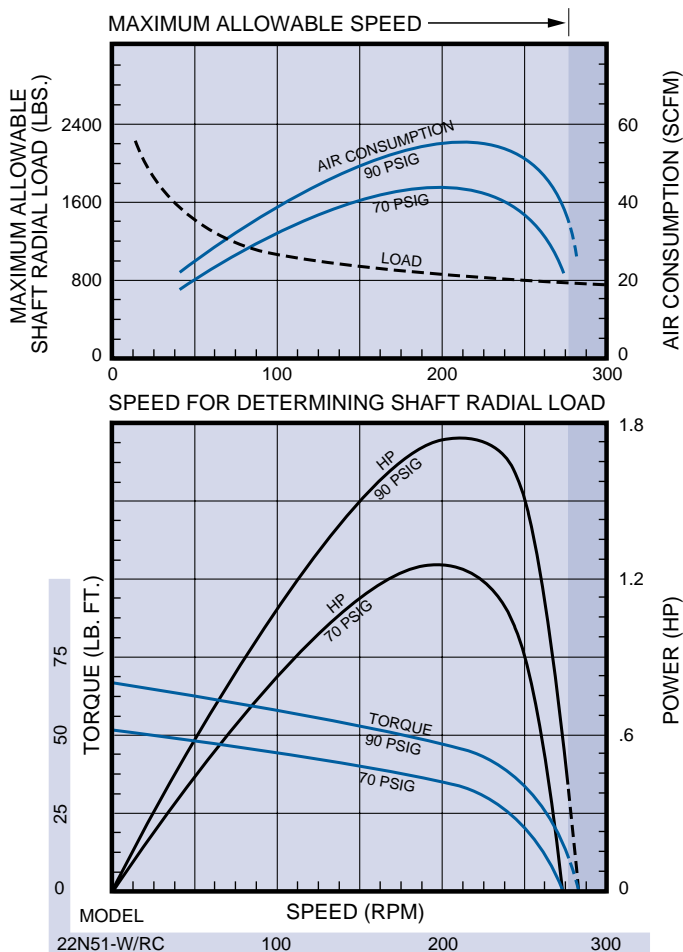

SERIES 551 MULTI-VANE AIR MOTORS

Round Keyed Shaft • 5.6 hp • Geared Drive, Governed
Base Mounted

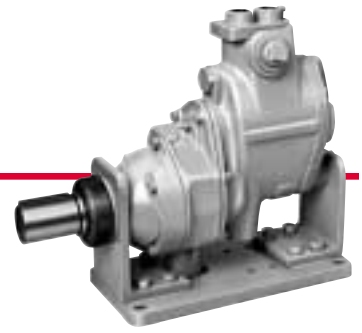

SPECIFICATIONS

Model	Max. Power		Speed at Max. Power	Free Speed▲	Starting Torque		Stall Torque		Air Consumption at Max. Power		Weight	
	hp	kw	rpm	rpm	lb.-ft.	Nm	lb.-ft.	Nm	scfm	m ³ /m	lb.	kg
Reversible												
551SM51-W/RC	5.6	4.18	95	120	400	542	545	739	160	4.53	93	42.2
551SO51-W/RC	5.6	4.18	59	77	650	881	885	1200	160	4.53	93	42.2

▲ ALL models must be operated with sufficient load to prevent speed from exceeding maximum allowable speed shown on performance curve. Performance figures are at 90 psig (620 kPa) air pressure.

SERIES 551 DIMENSIONS

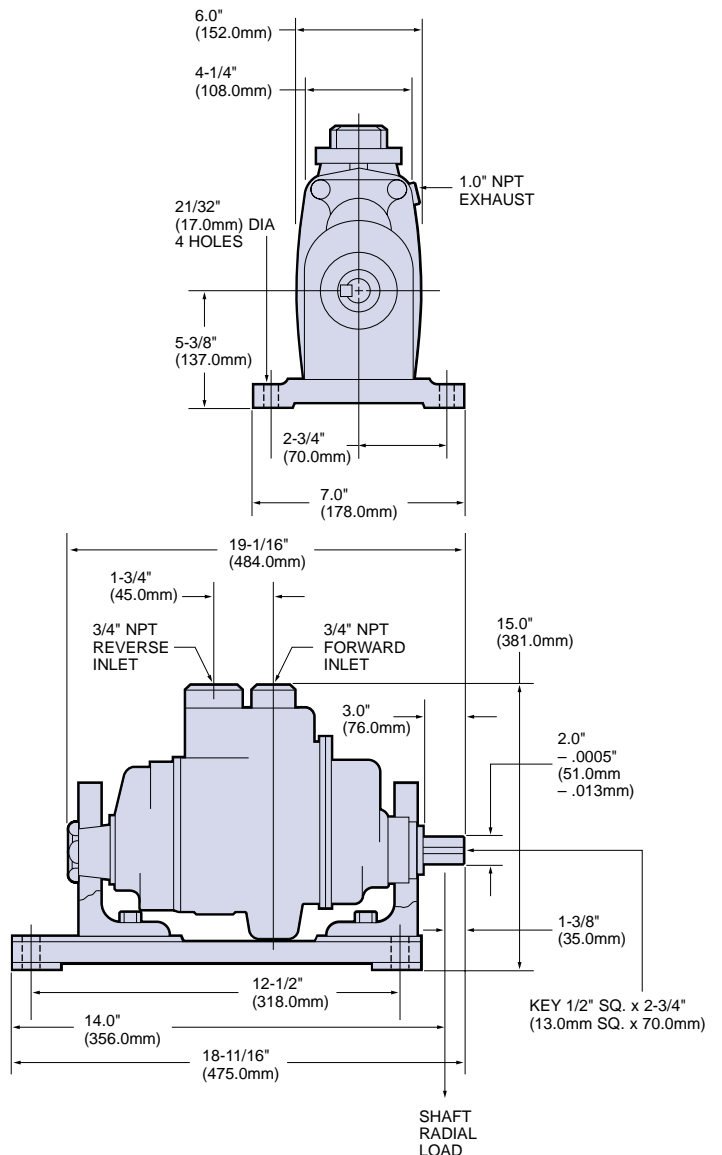
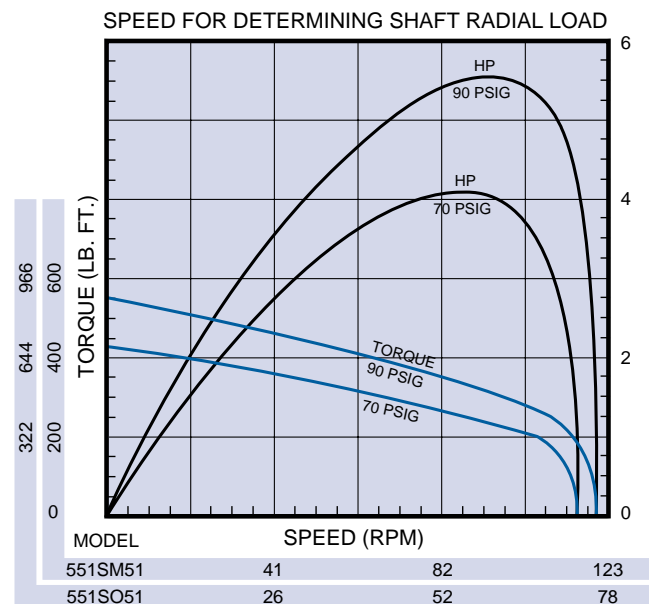
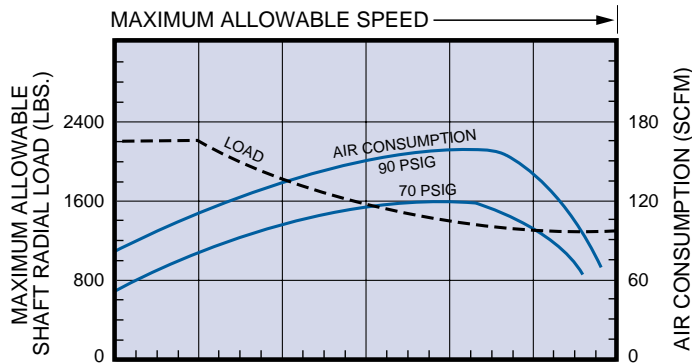

SERIES 92RM AND 992RM MULTI-VANE AIR MOTORS

Round Keyed Shaft • 8.15 to 9.9 hp
Geared Drive • Face Mounted

SPECIFICATIONS

Model	Max. Power		Speed at Max. Power	Free Speed▲	Starting Torque		Stall Torque		Air Consumption at Max. Power		Weight	
	hp	kw	rpm	rpm	lb.-ft.	Nm	lb.-ft.	Nm	scfm	m ³ /m	lb.	kg
Non-Reversible Direction of rotation is counterclockwise when facing the shaft.												
92RM1	9.9	7.38	2095	3980	33	44.7	45	61	240	6.79	24¼	11
92RM2	9.9	7.38	2095	3980	33	44.7	45	61	240	6.79	24¼	11
Reversible												
992RM1	8.15	6.08	1730	3600	28.7	38.9	39	52.9	230	6.51	25¼	11.3

▲ ALL models must be operated with sufficient load to prevent speed from exceeding maximum allowable speed shown on performance curve. Performance figures are at 90 psig (620 kPa) air pressure.

Direction of rotation of Model 92RM1 is clockwise, and of Model 92RM2 is counter clockwise when facing the shaft end of the motor.

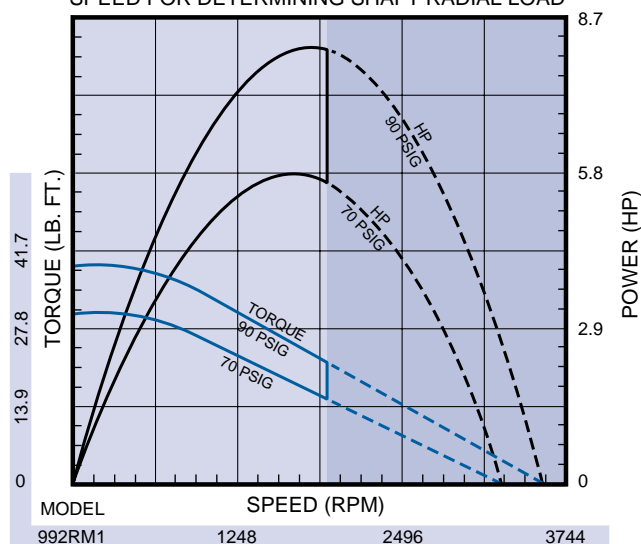
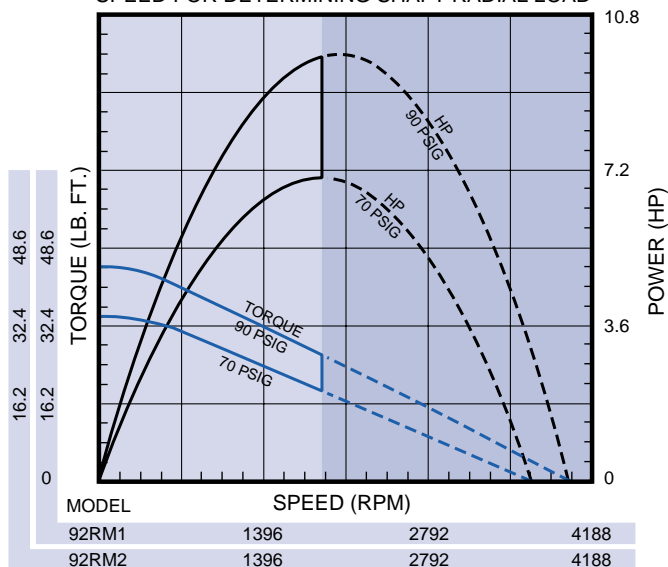
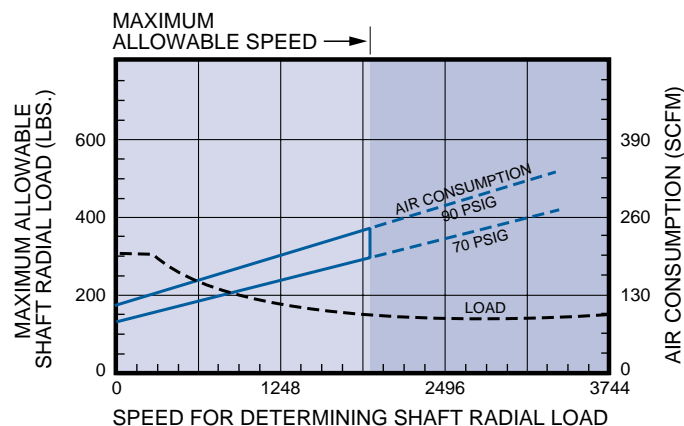
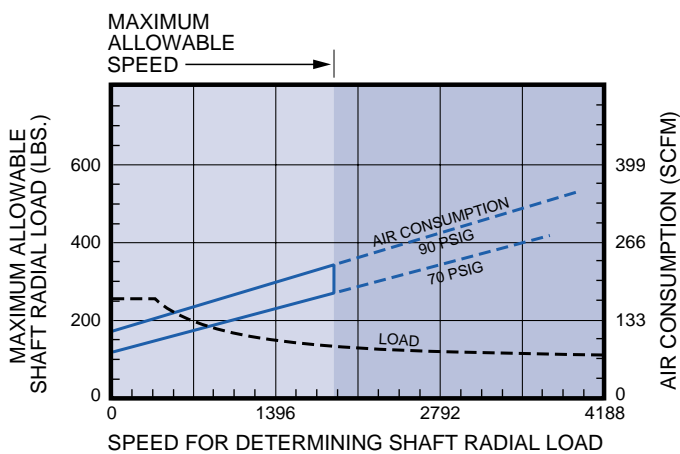

SERIES 92RM AND 992RM MULTI-VANE AIR MOTORS

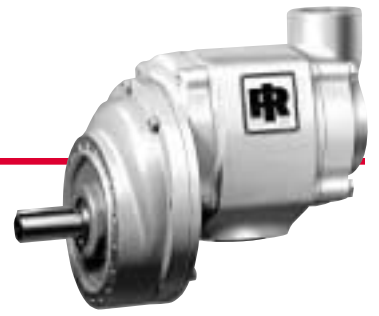

SERIES 92RM AND 992RM DIMENSIONS

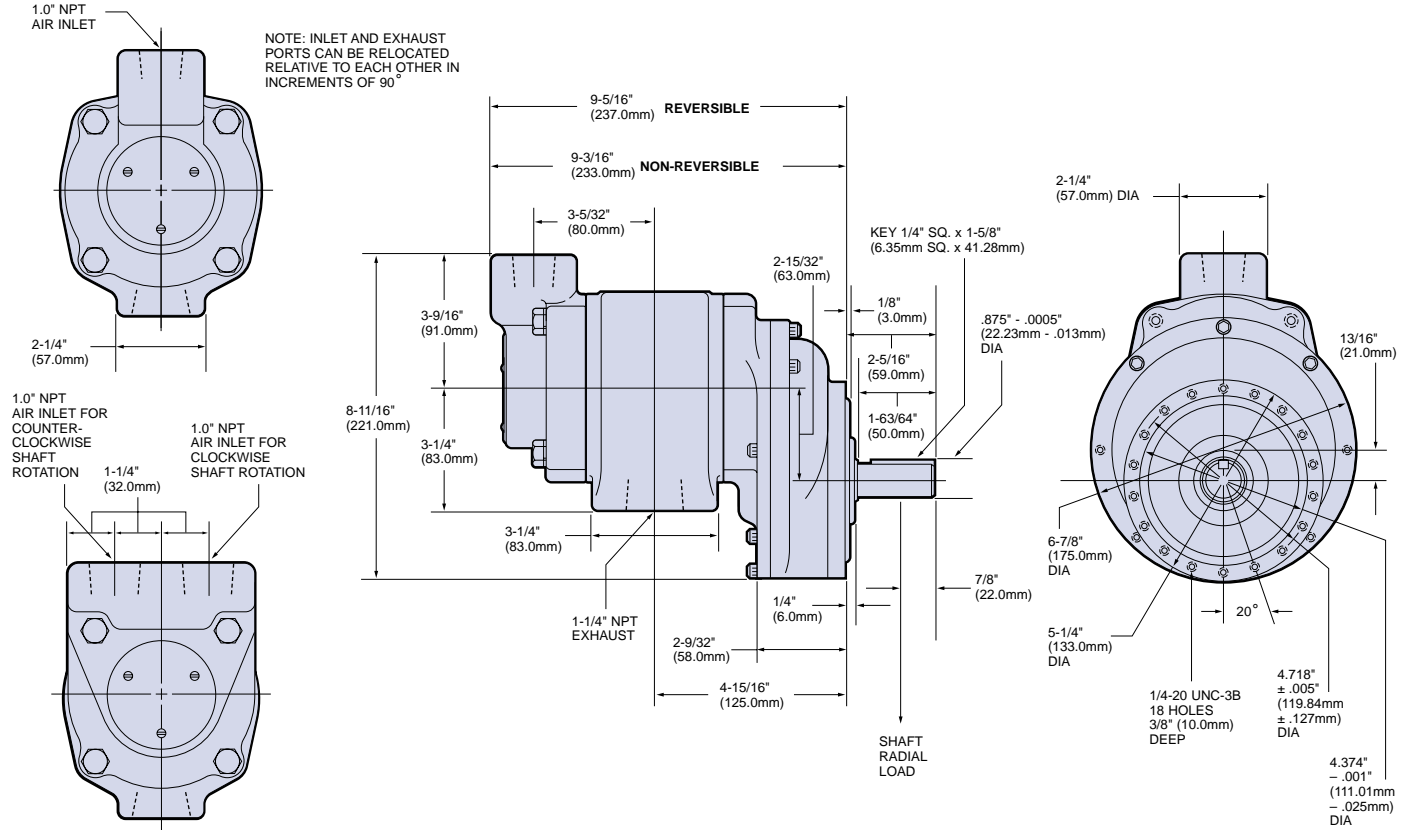

SERIES MRV MULTI-VANE AIR MOTORS

Round Keyed Shaft • .33 to 4.8 hp • Direct Drive
Flange or Base Mounted

SPECIFICATIONS

Series	Max. Power		Speed at Max. Power	Free Speed▲	Starting Torque		Stall Torque		Air Consumption at Max. Power		Weight	
	hp	kw	rpm	rpm	lb.-ft.	Nm	lb.-ft.	Nm	scfm	m ³ /m	lb.	kg
Reversible												
MRV003	0.33	0.25	7600	15,200	0.29	0.39	0.38	0.52	17	0.5	1½	0.6
MRV005	0.60	0.37	6000	12,500	0.45	0.61	0.60	0.81	42	1.2	1¾	0.8
MRV009	0.88	0.66	3000	8,070	1.7	2.3	2.3	3.1	48	1.4	7½	3.4
MRV015	1.5	1.1	3000	7900	2.6	3.5	4.1	5.6	67	1.9	8¾	2.4
MRV040	3.6	2.7	3000	7900	5.3	7.2	8.7	11.8	120	3.4	16¼	7.4
MRV050	4.8	3.6	2500	7000	10.0	13.6	14.0	19.0	152	4.3	22½	10.2

▲ ALL models must be operated with sufficient load to prevent speed from exceeding maximum allowable speed shown on performance curve. Performance figures are at 90 psig (620 kPa) air pressure.

MODEL DESIGNATION BREAKOUT

MRV
↑
MRV Series
Air Motors

003
↑
Nominal
Series Power

A
↑
Shaft/Interface

L
↑
Rotation

Nominal Series Power –
003 => 1/3 Horsepower
005 => 1/2 Horsepower
009 => 3/4 Horsepower
015 => 1-1/2 Horsepower
040 => 4 Horsepower
050 => 5 Horsepower

Shaft/Interface –
A => Round Shaft with Square Key
(Round Shaft on MRV003 Series)
B => Round Shaft with Woodruff Key (#3)
C => Round Shaft with Flat on Shaft

Rotation
– L => Left Hand Bias (CCW)
R => Right Hand Bias (CW)
None => Reversible

EQUIPMENT OPTIONS

Series	Furnished with Cataloged Models	Optional at Extra Price
MRV003	3 Hole Face Mounting MRV003A-AF350 Muffler	MRV003A-AG587 Mounting Foot
MRV005	3 Hole Face Mounting MRV003A-AF350 Muffler	MRV003A-AG587 Mounting Foot
MRV009	3 Hole Face Mounting MRV015A-AC980 Muffler	MRV015B-AH636 Mounting Foot MRV009B-AH635 Mounting Flange
MRV015	3 Hole Face Mounting MRV015A-AC980 Muffler	MRV015A-AH634 Mounting Foot MRV015A-AH633 NEMA 56C Mounting Flange
MRV040	3 Hole Face Mounting MRV040A-AC990 Muffler	MRV015A-AH634 Mounting Foot MRV015A-AH633 NEMA 56C Mounting Flange
MRV050	3 Hole Face Mounting MRV040A-AC990	MRV050A-AH640 Mounting Foot MRV050A-AH641 NEMA 182C, 184C, 143TC and 145TC Mounting Flange

SERIES MRV MULTI-VANE AIR MOTORS

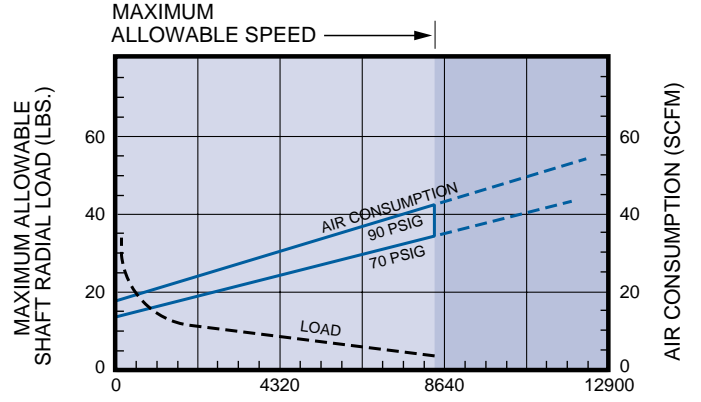
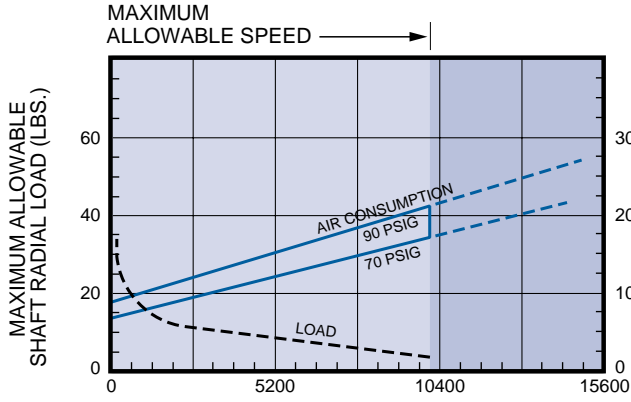
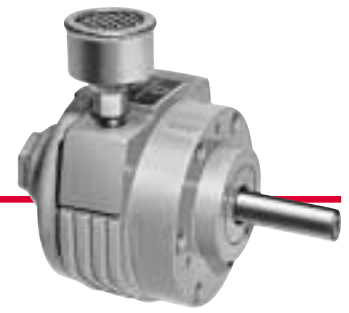

SPEED FOR DETERMINING SHAFT RADIAL LOAD

SPEED FOR DETERMINING SHAFT RADIAL LOAD

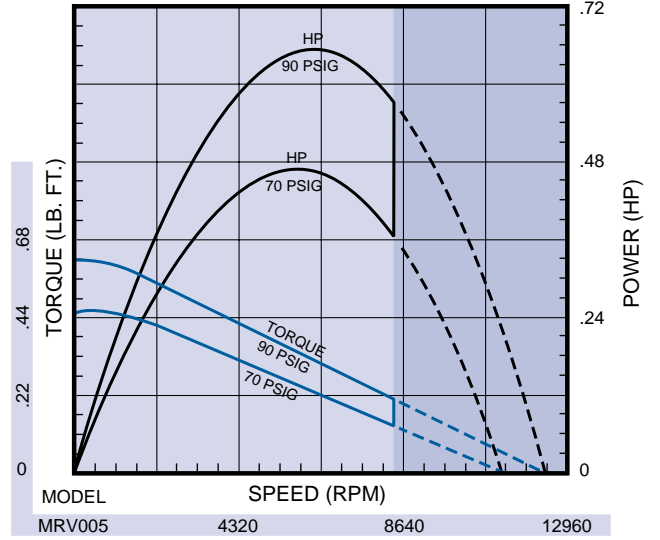
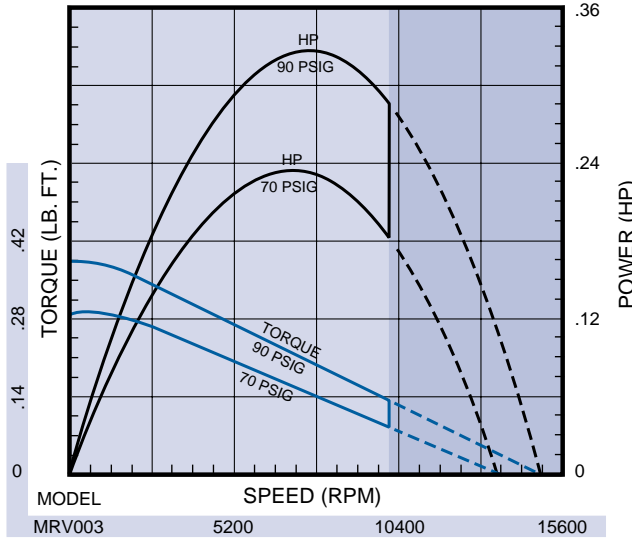

SERIES MRV MULTI-VANE AIR MOTORS

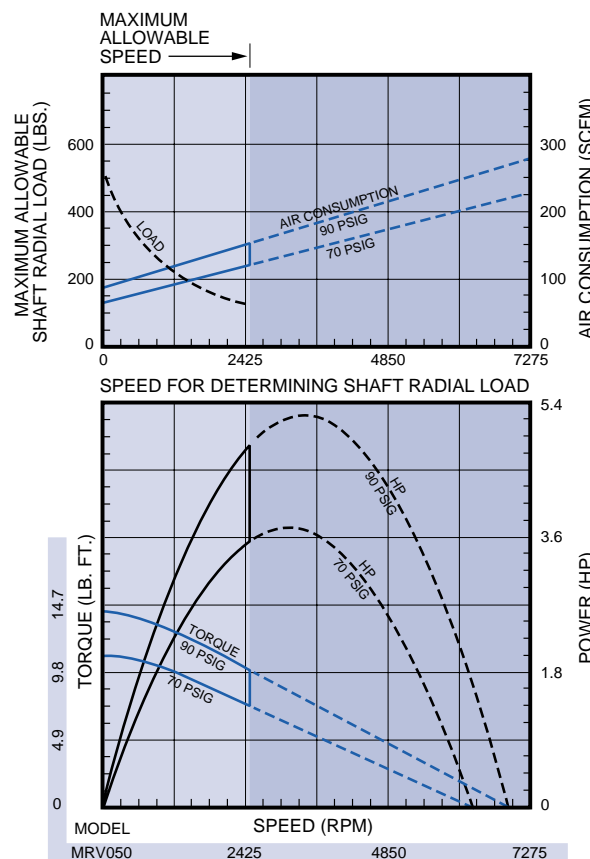
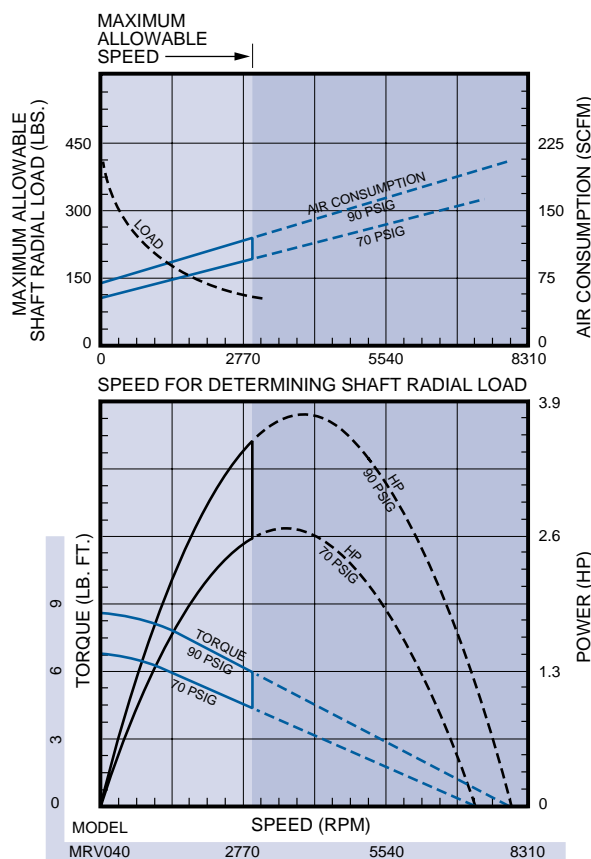
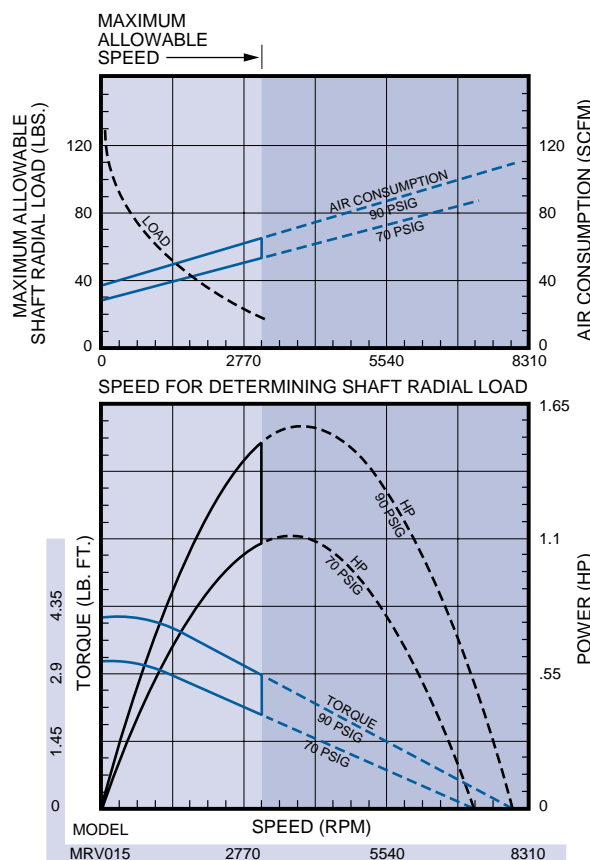
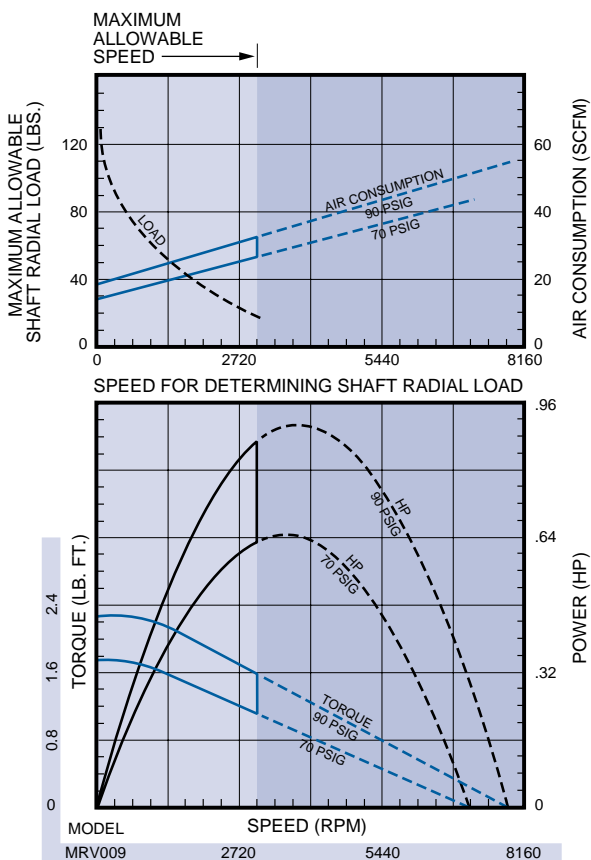

SERIES MRV MULTI-VANE AIR MOTORS

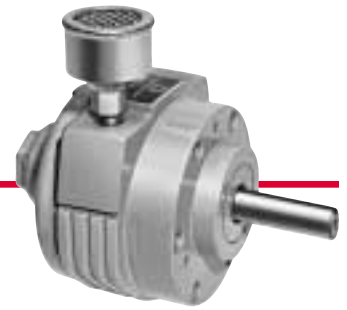

SERIES MRV003 DIMENSIONS

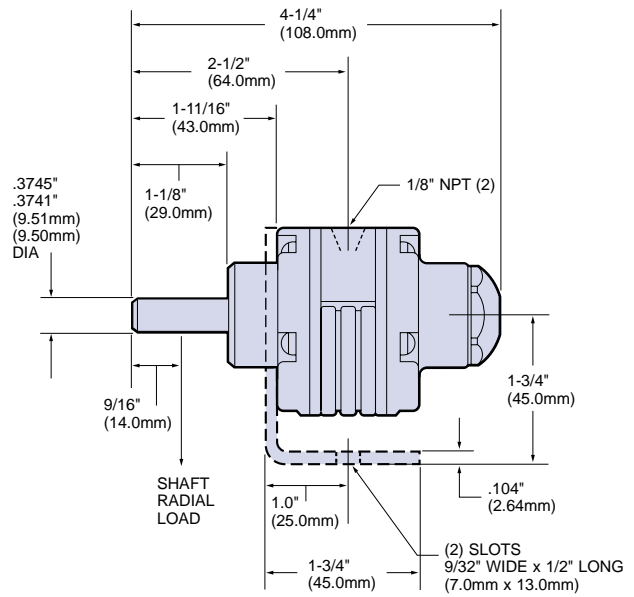
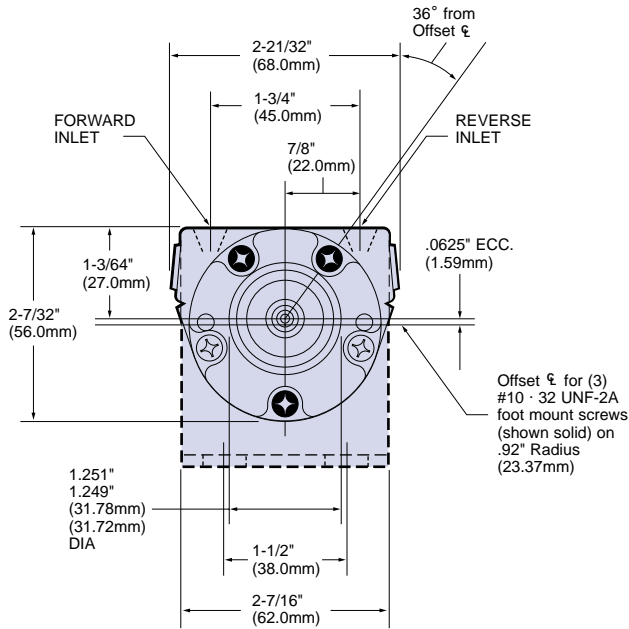

SERIES MRV005 DIMENSIONS

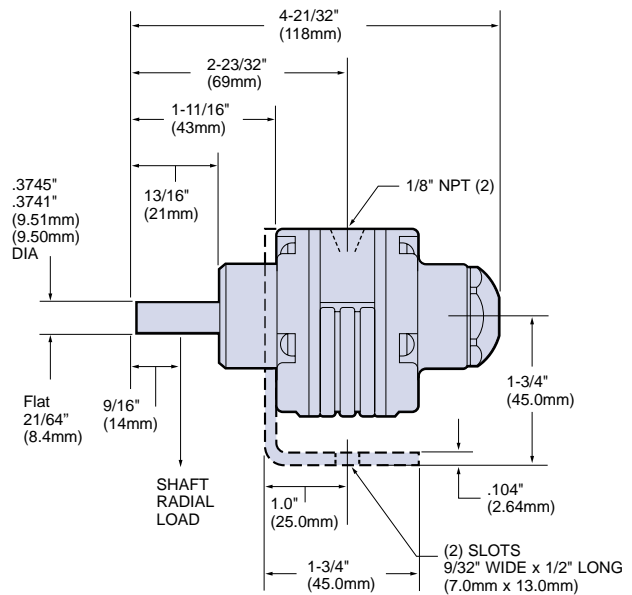
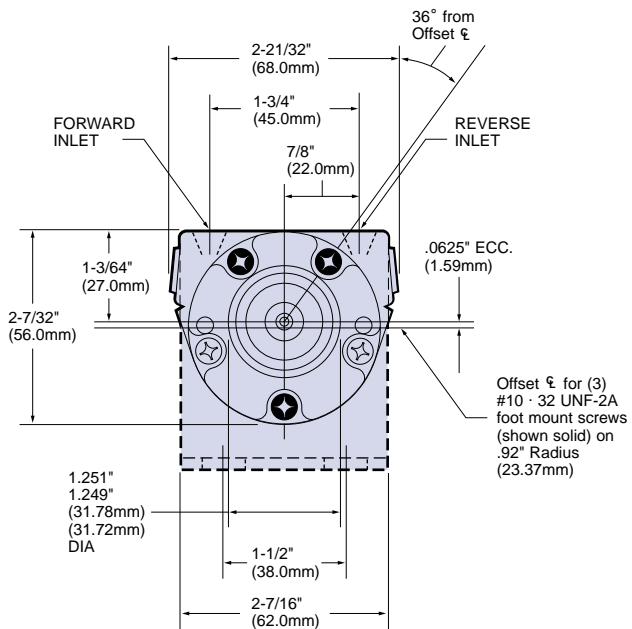

SERIES MRV MULTI-VANE AIR MOTORS

SERIES MRV009 DIMENSIONS

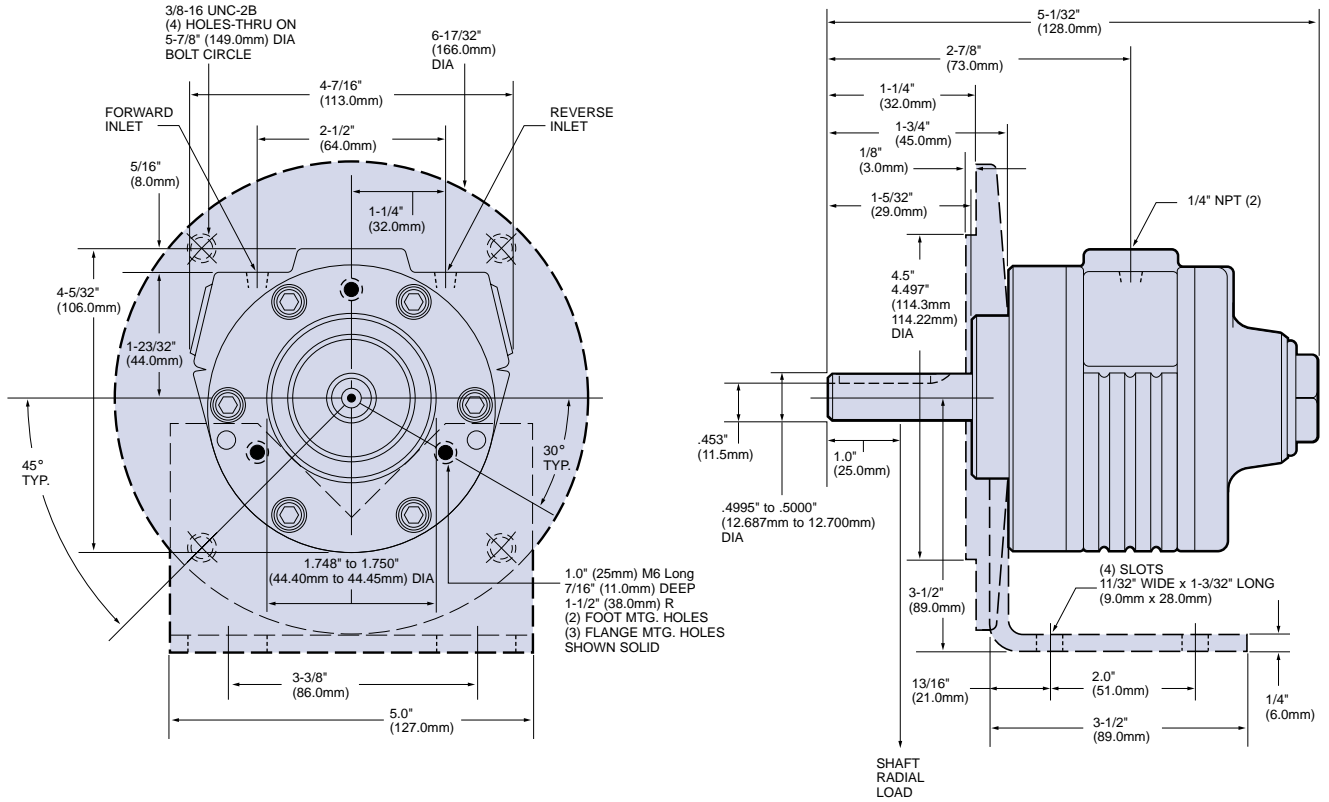

SERIES MRV015 DIMENSIONS

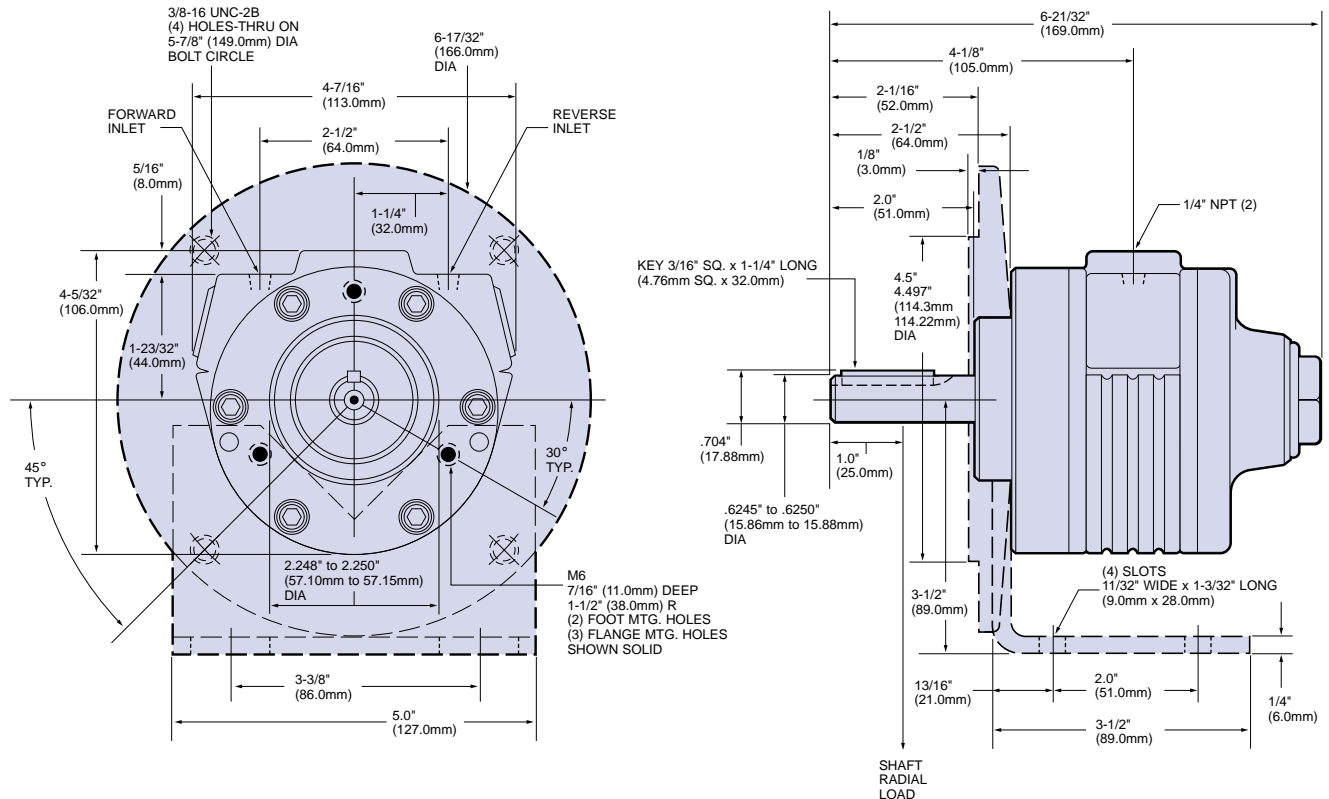

SERIES MRV MULTI-VANE AIR MOTORS

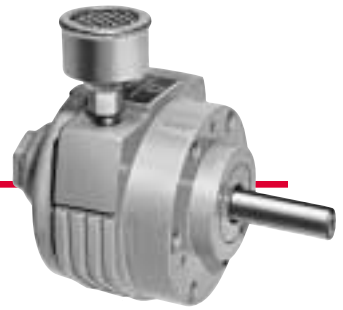

SERIES MRV040 DIMENSIONS

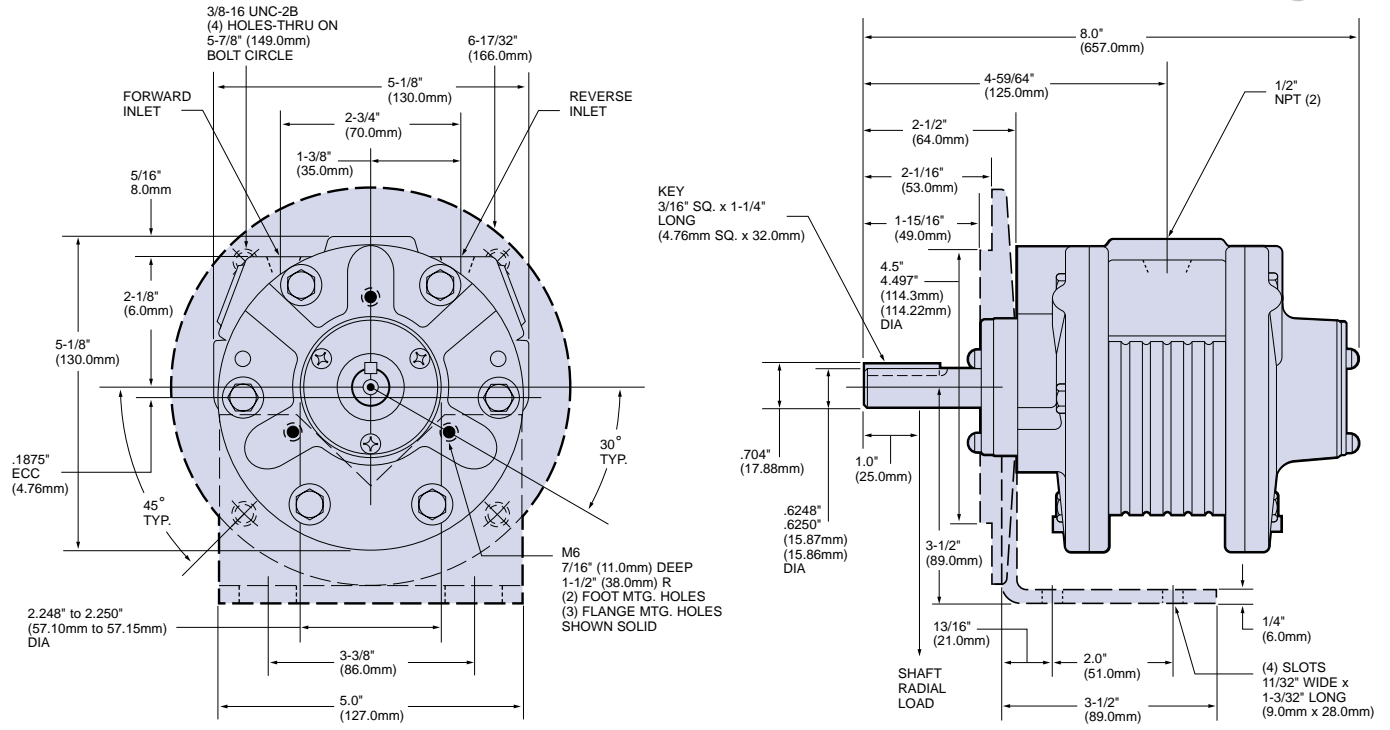

SERIES MRV050 DIMENSIONS

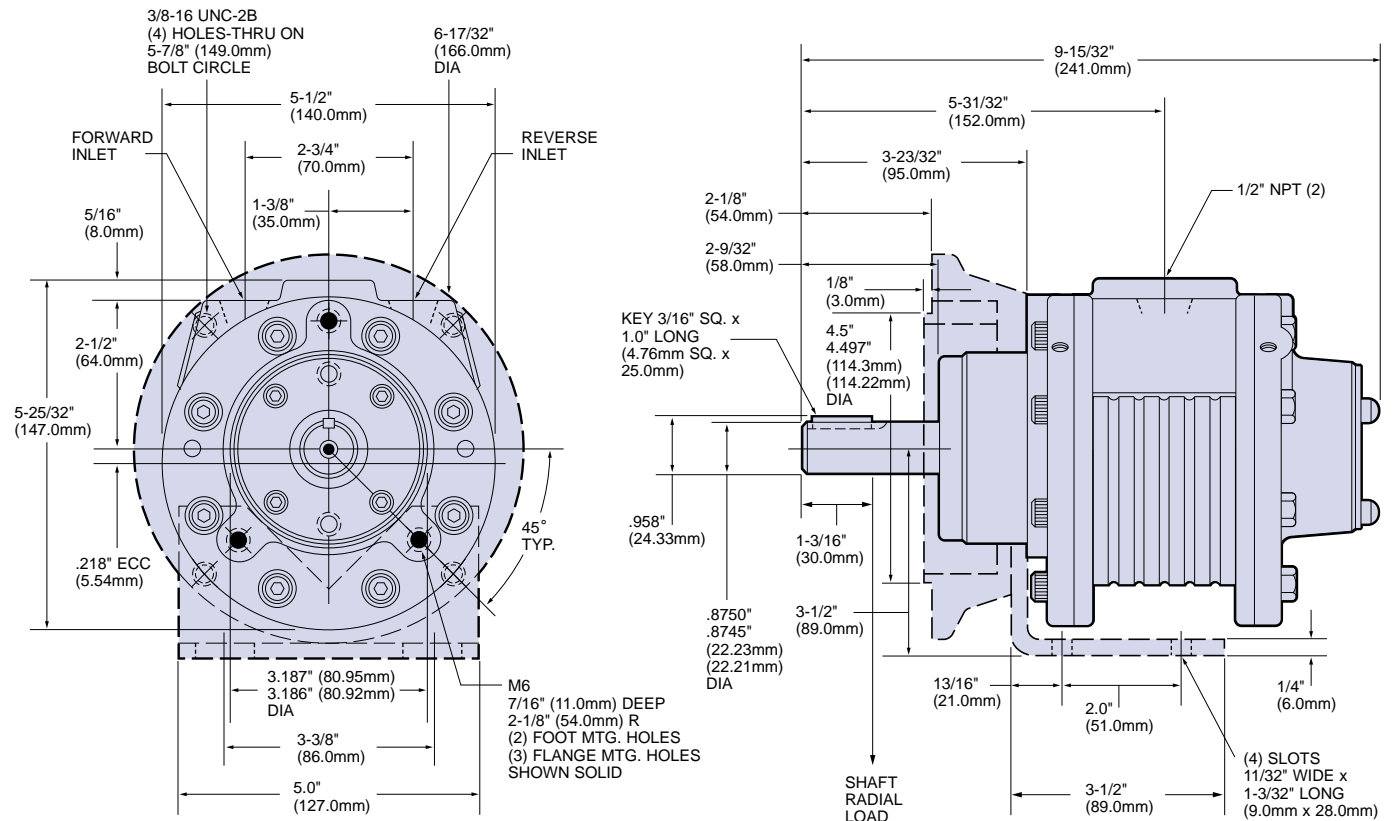

SERIES MVA AND MOV0 MULTI-VANE AIR MOTORS

Round Keyed Shaft • 1.93 to 10.5 hp • Direct Drive
Flange or Base Mounted

SPECIFICATIONS

Model*	Max. Power		Speed at Max. Power	Free Speed▲	Starting Torque		Stall Torque		Air Consumption at Max. Power		Weight	
	hp	kw	rpm	rpm	lb.-ft.	Nm	lb.-ft.	Nm	scfm	m ³ /m	lb.	kg
Reversible												
MVA017A	1.93	1.44	2800	5450	4.5	6.1	7	9.5	76	2.15	12½	5.67
MVA017B	1.93	1.44	2800	5450	4.5	6.1	7	9.5	76	2.15	12½	5.67
MVA034A	4.15	3.09	3000	6250	8.3	11.3	12.8	17.4	181	5.12	16½	7.48
MVA034B	4.15	3.09	3000	6250	8.3	11.3	12.8	17.4	181	5.12	16½	7.48
MOV005AA	.75	.56	3300	6800	1.65	2.2	2.2	2.98	30	.84	6½	2.95
MOV075AA	10.5	7.8	2600	5600	22.5	30.5	30	40.7	260	7.36	64	29

▲ ALL models must be operated with sufficient load to prevent speed from exceeding maximum allowable speed shown on performance curve. Performance figures are at 90 psig (620 kPa) air pressure.

* "A" suffix denotes foot mount model, "B" suffix denotes flange mount models.

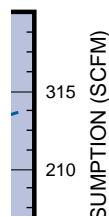
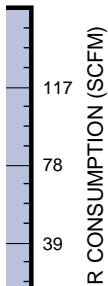

SERIES MVA AND MOV0 MULTI-VANE AIR MOTORS

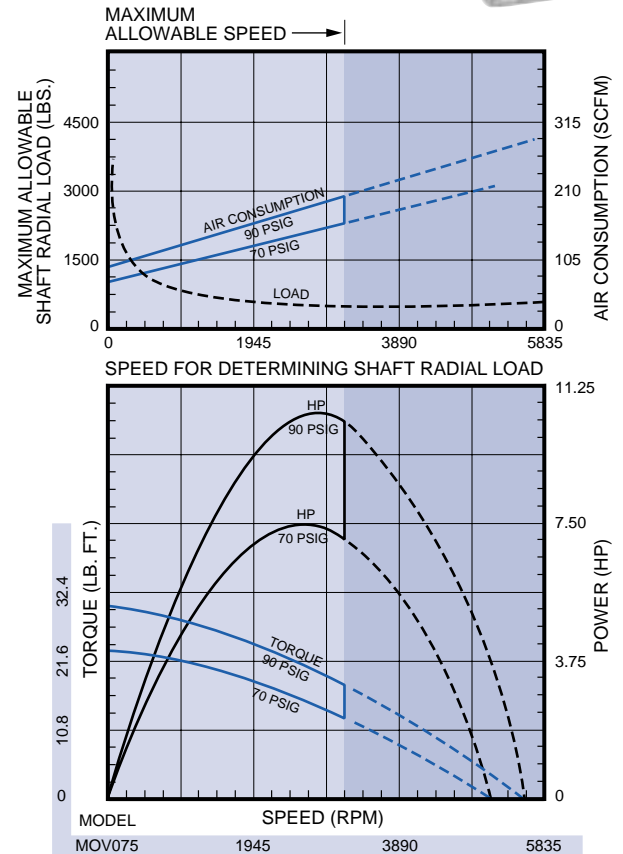
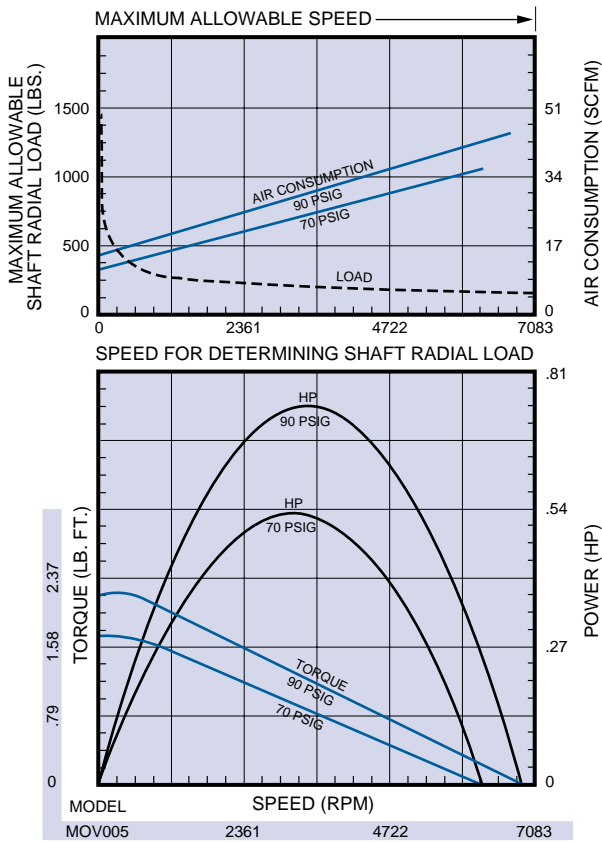
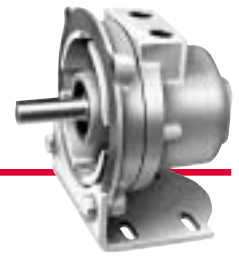

SERIES MVA DIMENSIONS

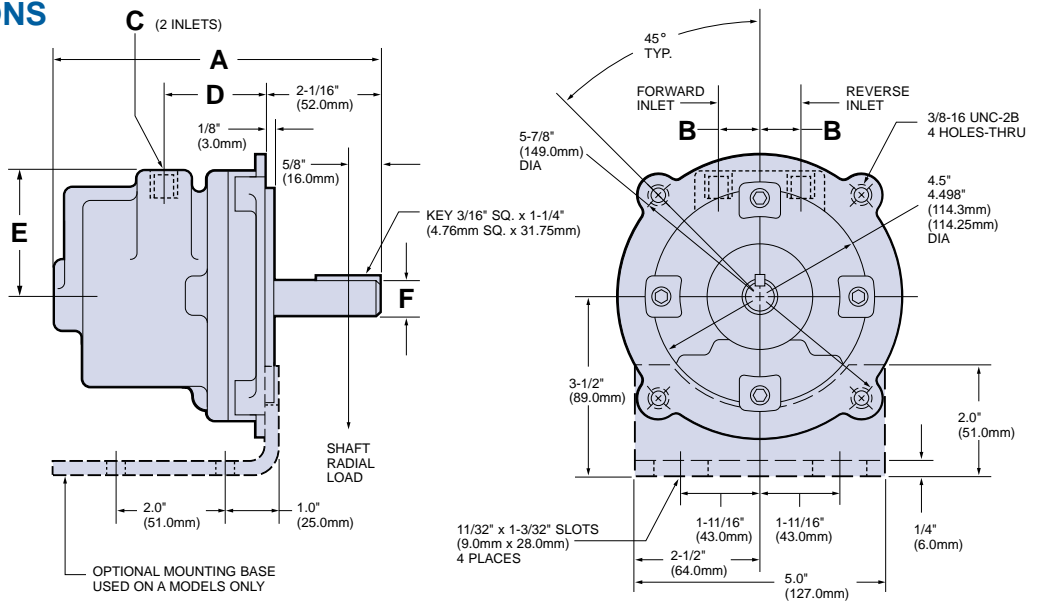

DIMENSIONS

SERIES	A		B		C	D		E		F DIA.	
	in.	mm	in.	mm	NPT	in.	mm	in.	mm	in.	mm
MVA017	6 1/16	170	7/8	22	3/8"	1 1/8	48	2 1/2	64	.6250 .6245	15.88 15.86
MVA034	8 7/16	214	1 3/16	30	1/2"	2	51	2 5/8	67	.8750 .8745	22.23 22.21

SERIES MVA AND MOV0 MULTI-VANE AIR MOTORS

MODEL MOV005AA DIMENSIONS

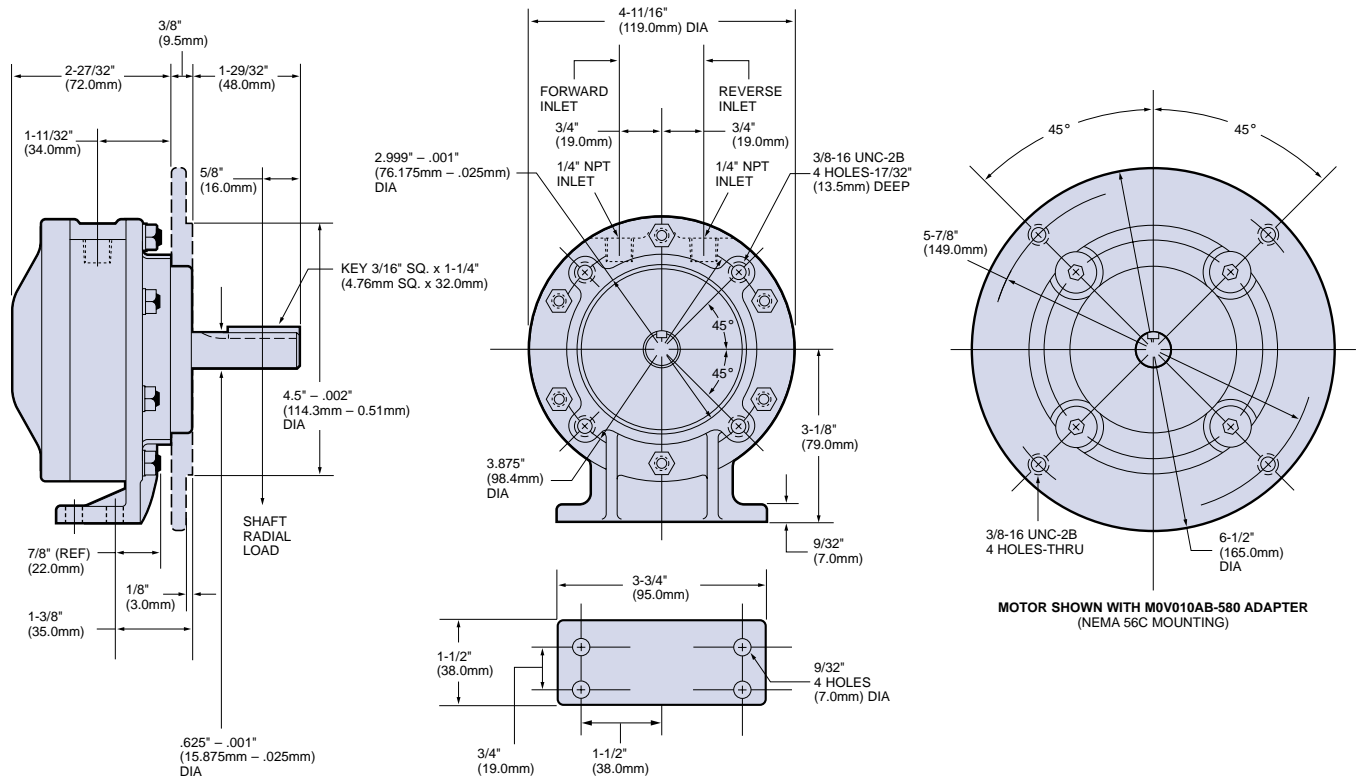

EQUIPMENT OPTIONS

Models	Furnished with Cataloged Models	Optional at Extra Price
MVA017A	*Foot Mounting	
MVA017B	NEMA C Face 56C Frame Size	MVA008-K4 Mounting Foot Kit
MVA034A	**Foot Mounting	MOV010AA-674 Muffler
MVA034B	NEMA C Face 182C Frame Size	MVA008-K4 Mounting Foot Kit MOV010AA-674 Muffler
MOV005AA	Foot/4 Hole Face Mounting	MRV015-AC 980 Muffler
MOV075AA	Foot/6 Hole Face Mounting	150BM-A674 Muffler

* Removal of Foot Mounting results in Motor having NEMA C Face Mounting, 56C Frame Size.

** Removal of Foot Mounting results in Motor having NEMA C Face Mounting, 182C Frame Size.

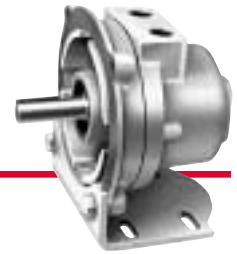

MODEL MOV075AA DIMENSIONS

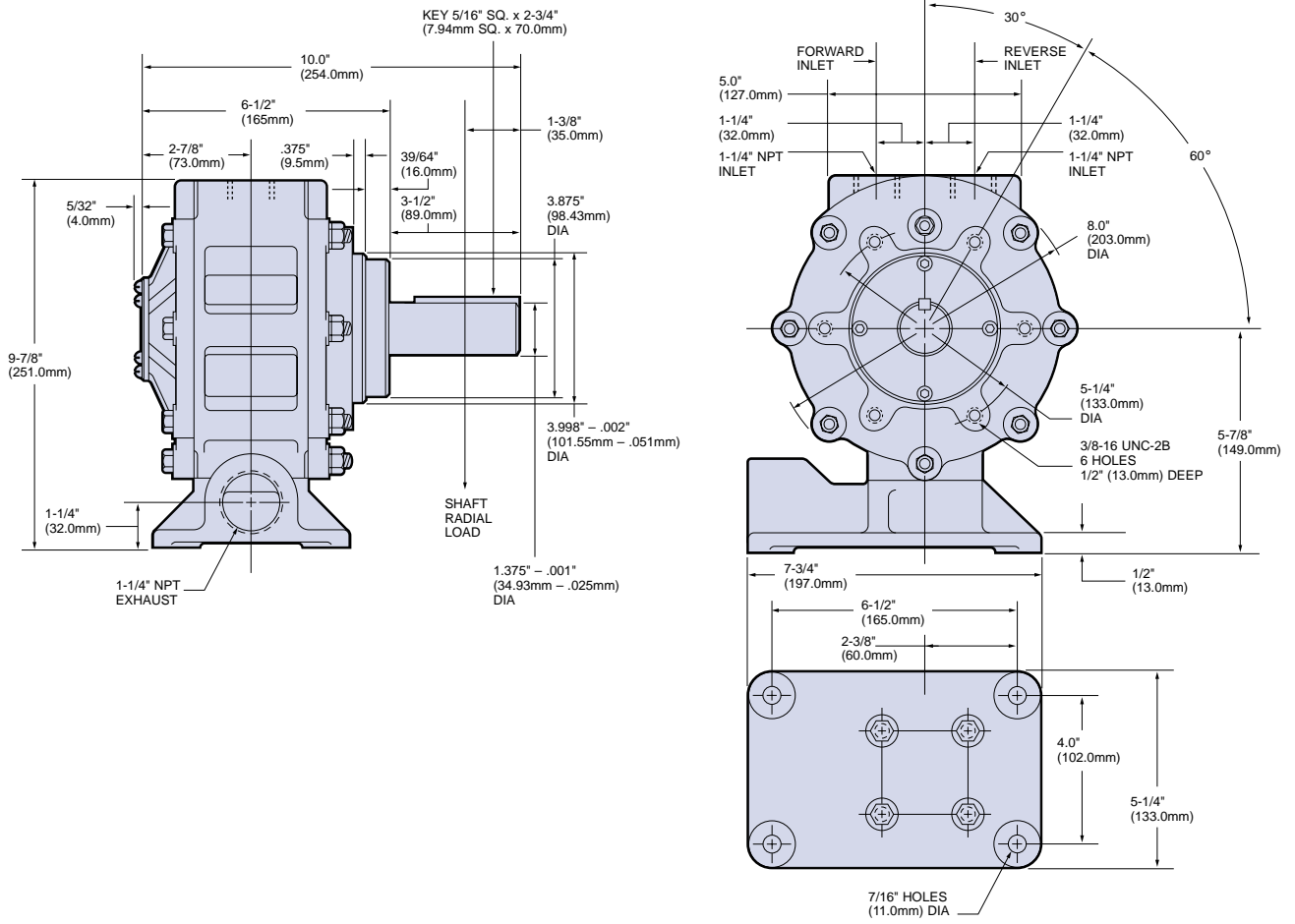

DIRECT AND GEARED DRIVE PISTON AIR MOTORS

Round Keyed Shaft • 2.05 to 25 hp • Direct and Geared Drive
 Typical Direct Drive • Base Mounted

SPECIFICATIONS

Model	Max. Power		Speed at Max. Power	Free Speed▲	Starting Torque		Stall Torque		Air Consumption at Max. Power		Weight	
	hp	kw	rpm	rpm	lb.-ft.	Nm	lb.-ft.	Nm	scfm	m ³ /m	lb.	kg
Direct Drive Reversible												
CCM	2.05	1.53	1075	2140	13.2	17.9	18.8	25.5	97	2.7	135	61.2
DD6M	2.6	1.94	750	1490	24	32.5	34.2	46.4	79	2.2	135	61.2
EEM	4.4	3.28	735	1450	41	55.6	59	80	137	3.9	200	90.7
EE5M	7.8	5.82	950	1875	60	81.4	80.5	109.2	220	6.2	210	95.3
HHM	11.3	8.43	730	1450	106	144	152	206	270	7.6	235	107
HH5M	15.2	11.33	750	1500	146	198	195	264	400	11.3	250	113
KK6M	25	18.64	755	1500	260	353	325	441	680	19.3	475	216
Geared Drive Reversible												
EE3G	5	3.73	275	560	122	165	175	237	155	4.4	200	90.7
EE53G	6.8	5.07	305	600	154	209	205	278	220	6.2	220	99.8
EE9G	4.7	3.51	92	190	357	484	510	692	155	4.4	210	95.3
EE59G	6.5	4.85	100	200	450	610	600	814	220	6.2	230	104

▲ ALL models must be operated with sufficient load to prevent speed from exceeding maximum allowable speed shown on performance curve.
 All of the above motors are furnished less valve and piping as standard.
 Performance figures are at 90 psig (620 kPa) air pressure.

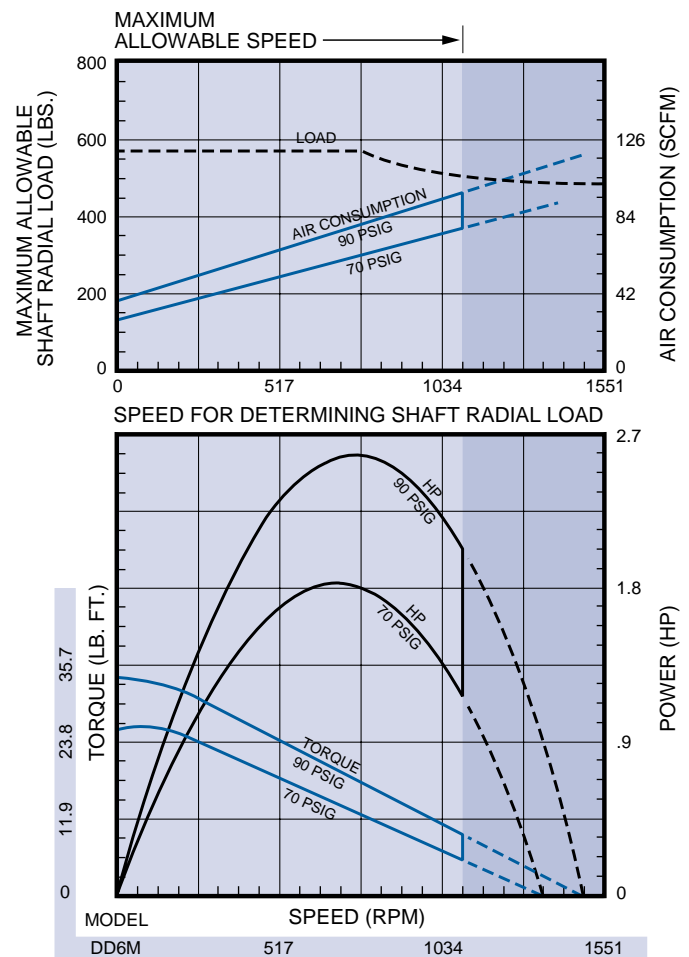
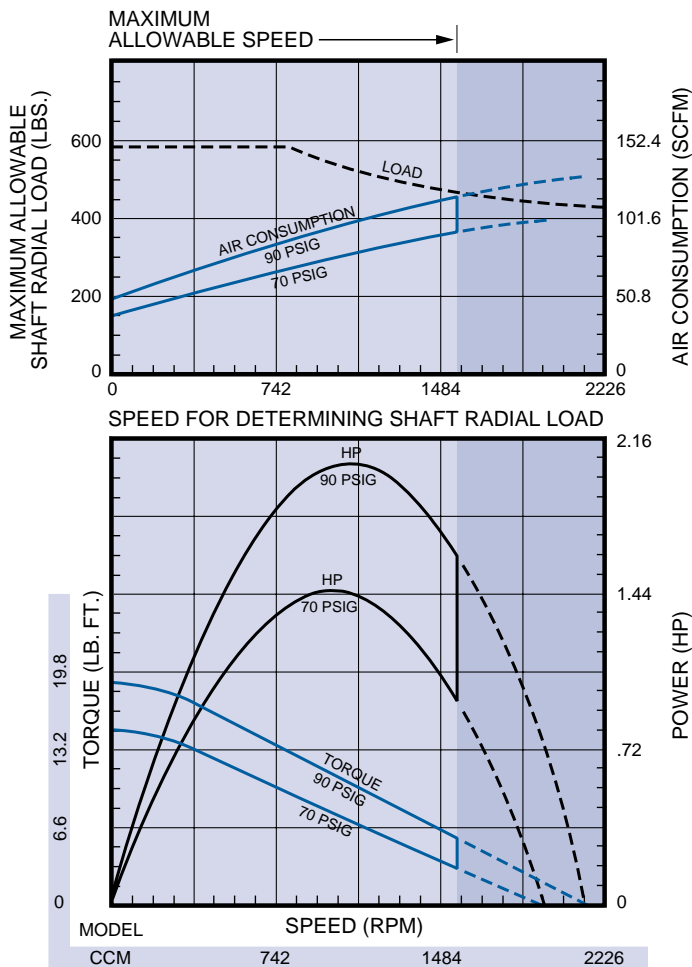

DIRECT AND GEARED DRIVE PISTON AIR MOTORS

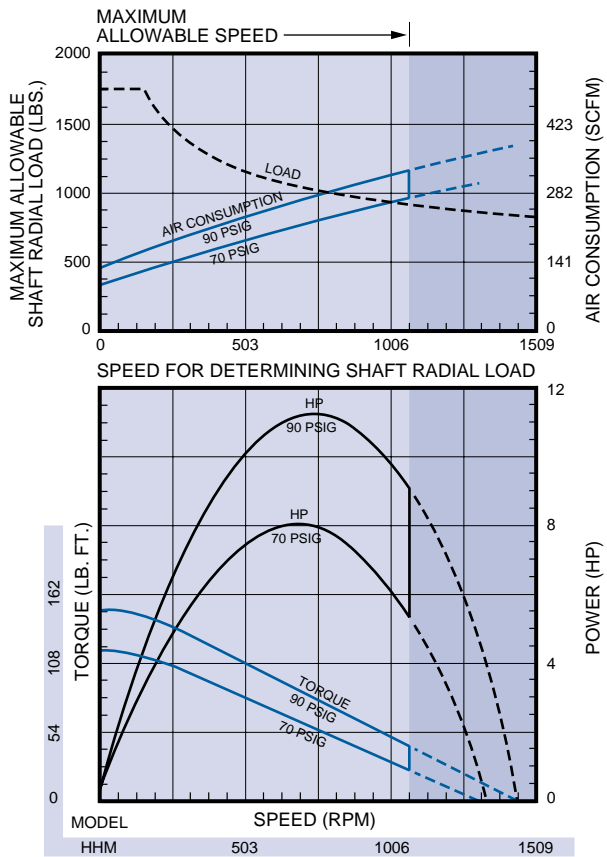
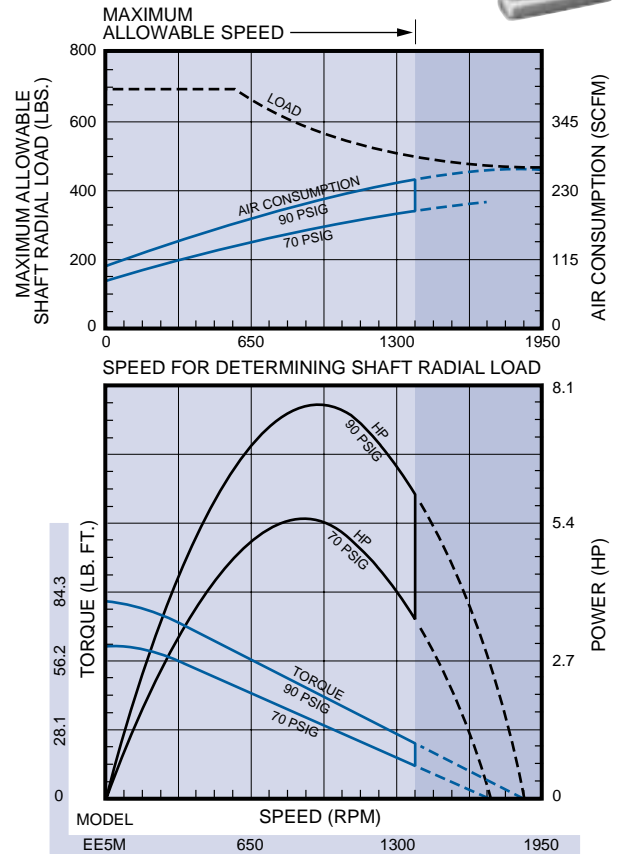
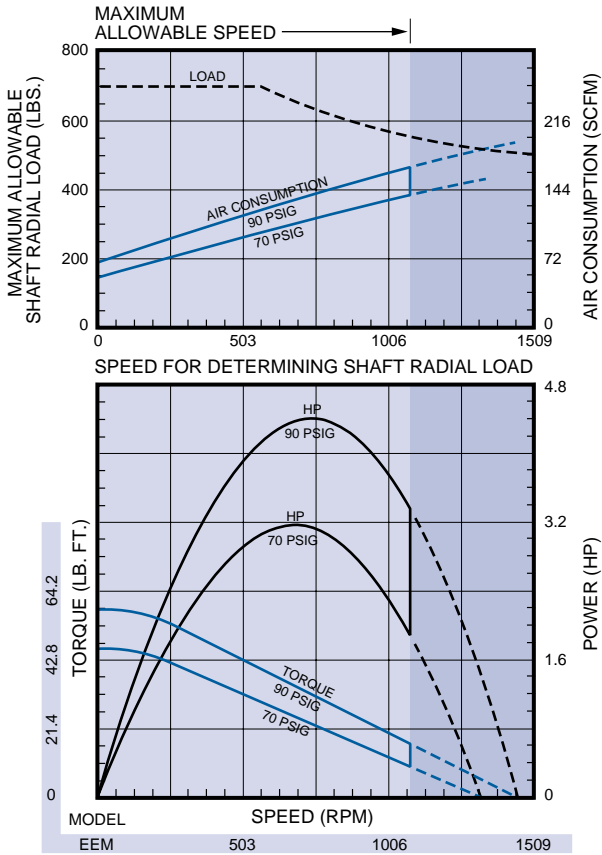
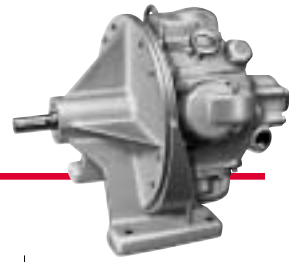

DIRECT AND GEARED DRIVE PISTON AIR MOTORS

Typical Direct Drive

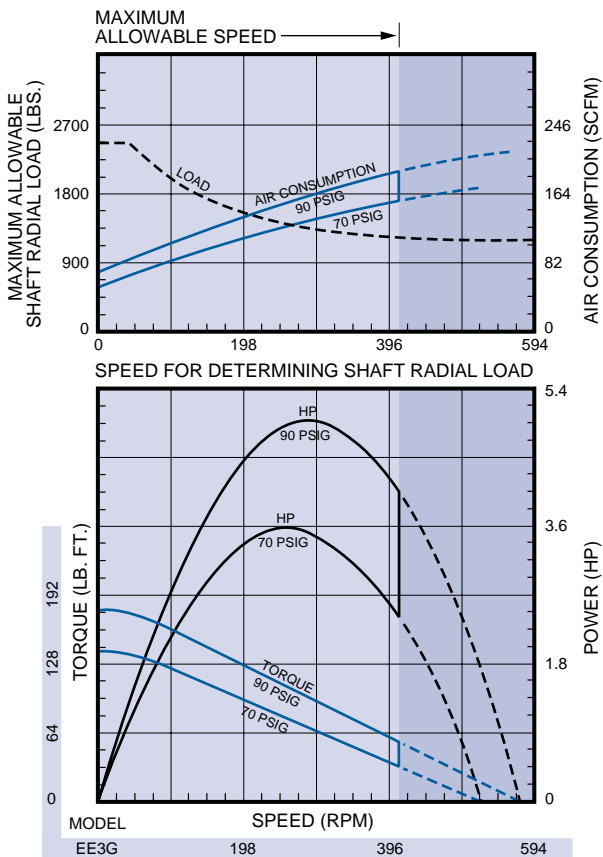
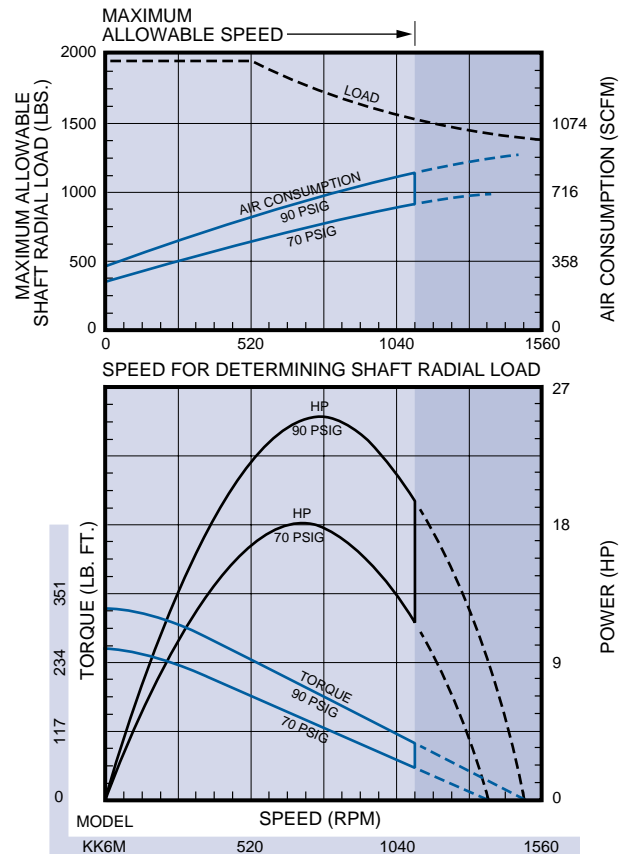
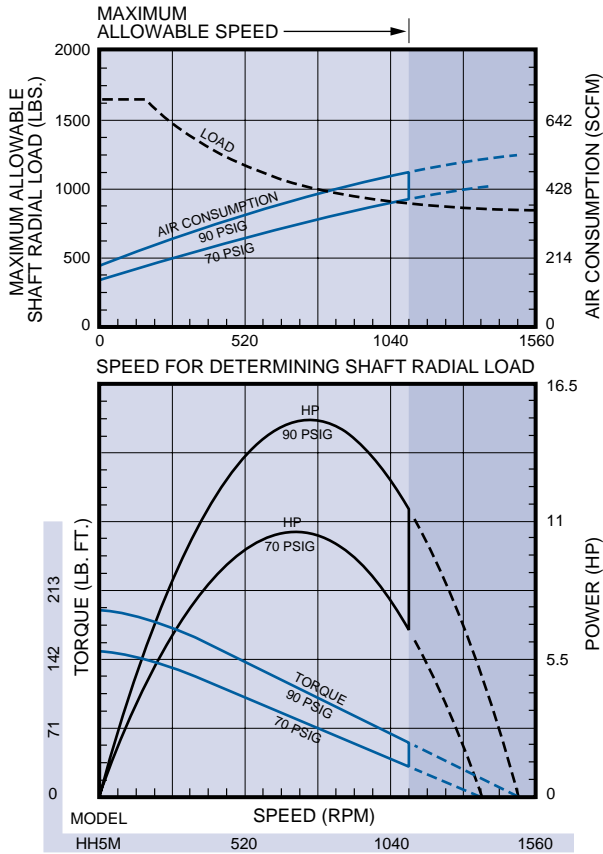

DIRECT AND GEARED DRIVE PISTON AIR MOTORS

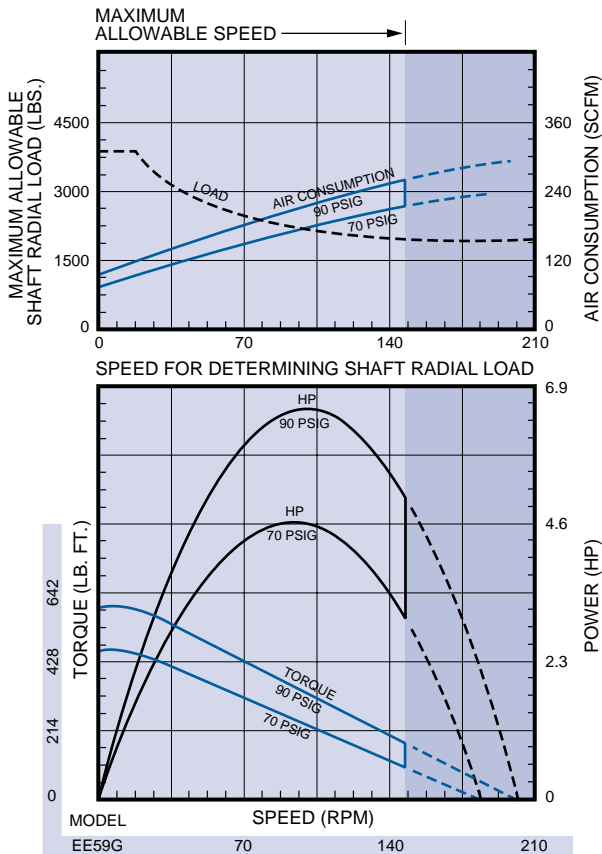
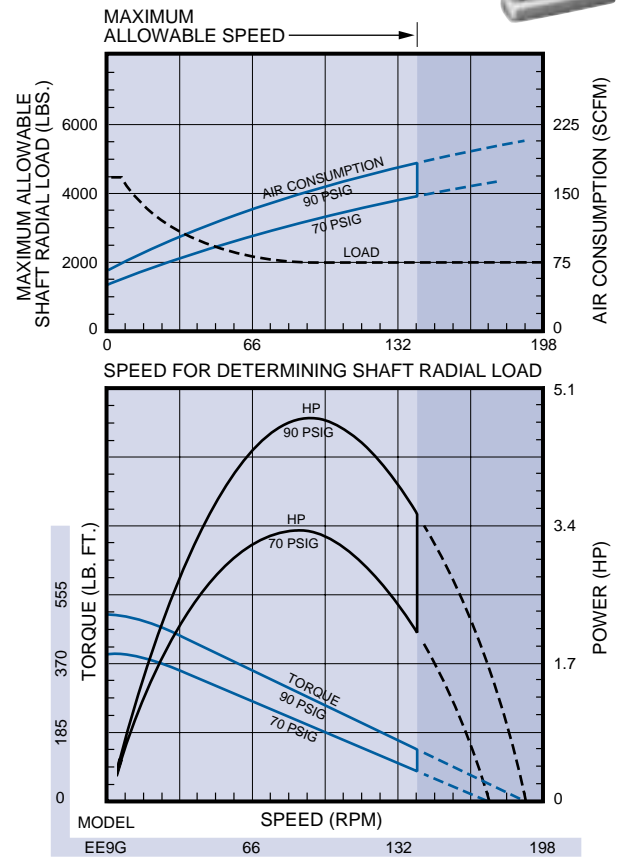
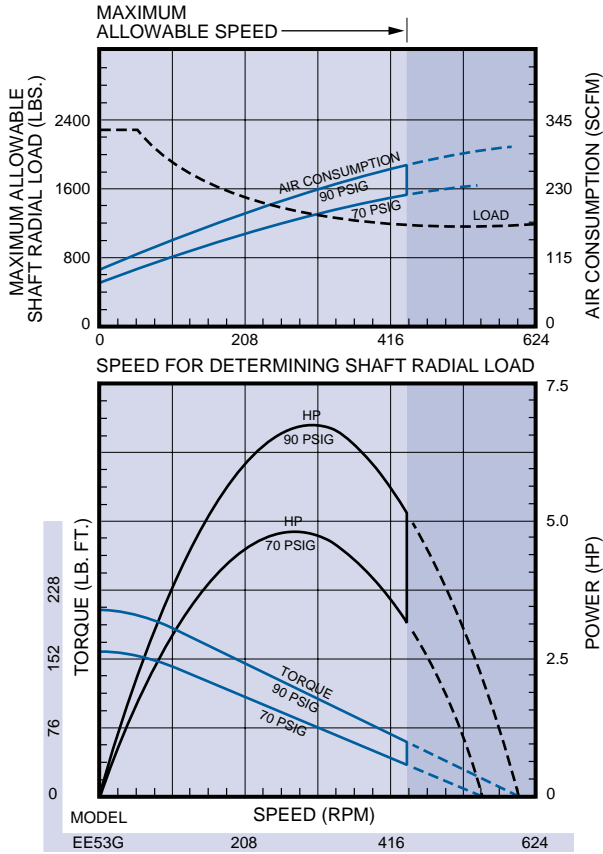
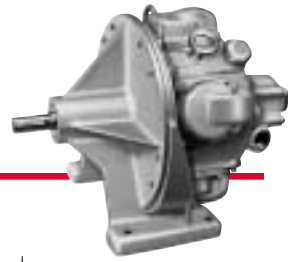

DIRECT AND GEARED DRIVE PISTON AIR MOTORS

Typical Geared Drive

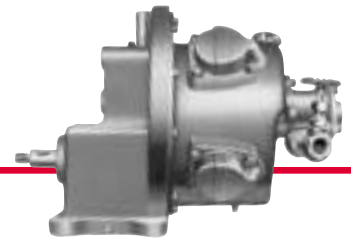

DIRECT DRIVE DIMENSIONS

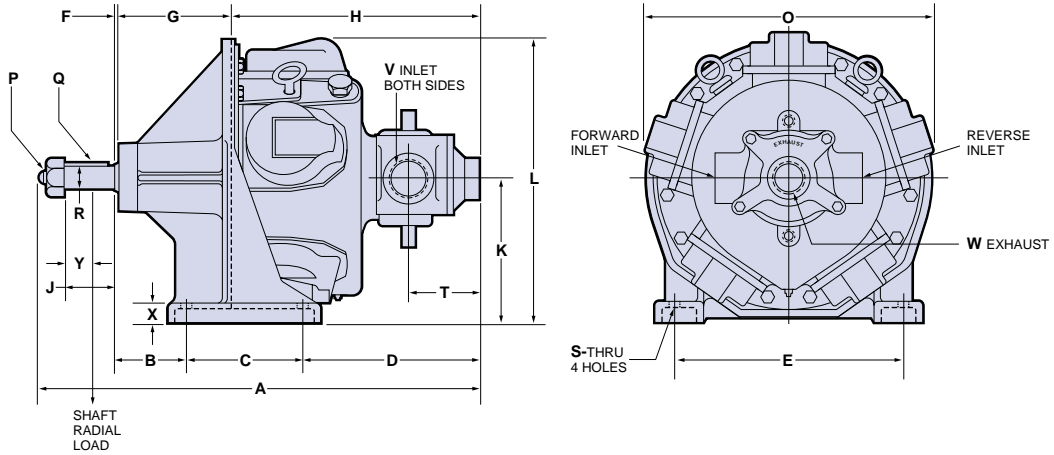

DIMENSIONS IN INCHES

Model	A	B	C	D	E	F	G	H	J	K	L	O	P** Thd.	Q Key	R*	S Dia.	T	V NPT	W NPT	X	Y
CCM, DD6M	23 ³ / ₁₆	3 ³ / ₄	7 ³ / ₄	7 ⁷ / ₁₆	10 ¹ / ₂	2 ⁵ / ₃₂	7 ¹³ / ₃₂	11 ³ / ₁₆	3	8 ³ / ₄	15 ⁵ / ₁₆	13 ³ / ₄	1"-8	1/4 x 1/4	1.125	2 ⁵ / ₃₂	2 ¹ / ₁₆	3/4	1	7/8	2 ¹¹ / ₁₆
EEM, EE5M	27	3 ¹³ / ₁₆	9 ⁹ / ₁₆	9 ⁹ / ₁₆	12 ¹ / ₂	2 ⁵ / ₃₂	9 ¹⁷ / ₃₂	12 ¹⁷ / ₃₂	3	9 ⁹ / ₁₆	16 ¹³ / ₁₆	15	1"-8	1/4 x 1/4	1.125	2 ⁵ / ₃₂	2 ¹⁵ / ₁₆	1	1	7/8	2 ¹¹ / ₁₆
HHM	24 ³ / ₁₆	4 ⁷ / ₁₆	7	9 ⁷ / ₁₆	13 ¹ / ₂	3/16	7	14	3	8 ⁷ / ₁₆	17 ⁷ / ₁₆	17 ⁷ / ₁₆	+	3/8 x 3/8	1.375	2 ¹ / ₃₂	3 ¹³ / ₁₆	1	1 ¹ / ₄	1 ¹ / ₄	1 ¹ / ₁₆
HH5M	24 ³ / ₁₆	4 ⁷ / ₁₆	7	9 ⁷ / ₁₆	13 ¹ / ₂	3/16	7	14	3	8 ⁷ / ₁₆	17 ⁷ / ₁₆	17 ⁷ / ₁₆	+	3/8 x 3/8	1.375	2 ¹ / ₃₂	3 ¹³ / ₁₆	1	1 ¹ / ₄	1 ¹ / ₄	1 ¹ / ₁₆
KK6M	30 ³ / ₄	4 ³ / ₄	8 ⁷ / ₁₆	12 ⁵ / ₁₆	13 ¹ / ₂	1/8	7 ¹ / ₁₆	18 ³ / ₁₆	4 ¹ / ₄	12 ¹ / ₂	22 ¹ / ₄	22	+	3/8 x 3/8	1.625	2 ¹ / ₃₂	4 ⁷ / ₁₆	1 ¹ / ₄	1 ¹ / ₂	1 ³ / ₈	1 ¹ / ₈

+ The end of the shaft is not threaded on these Motors and no nut is used. *Tolerance: +0 -.0005" **Thd.-UNC2A.

DIMENSIONS IN MILLIMETERS

Model	A	B	C	D	E	F	G	H	J	K	L	O	P Thd.	Q Key	R*	S Dia.	T	X	Y
CCM, DD6M	599	95	197	200	267	20	188	284	76	222	397	349	1"-8	6 x 6	28	20	68	22	68
EEM, EE5M	686	97	248	236	318	20	242	318	76	237	427	381	1"-8	6 x 6	28	20	75	22	68
HHM	614	110	178	251	343	5	178	356	76	225	438	438	+	10 x 10	35	17	97	32	33
HH5M	614	110	178	251	343	5	178	356	76	225	438	438	+	10 x 10	35	17	97	32	33
KK6M	768	121	219	321	343	3	195	462	108	308	565	559	+	10 x 10	41	17	110	35	48

+ The end of the shaft is not threaded on these Motors and no nut is used. *Tolerance: +0 -0.13mm

GEARED DRIVE DIMENSIONS

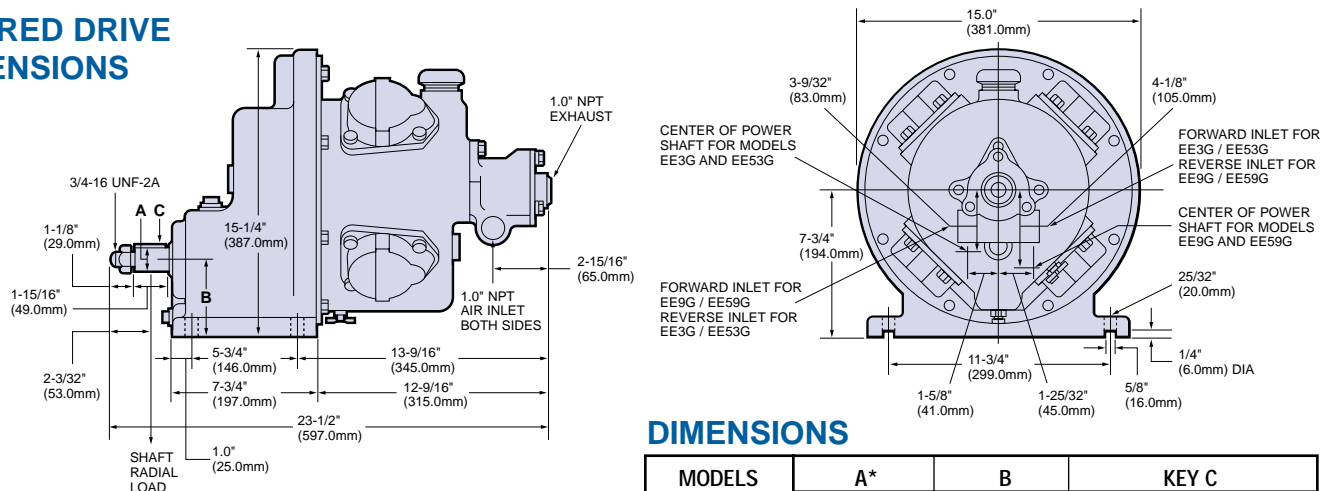

DIMENSIONS

MODELS	A*		B		KEY C	
	in.	mm	in.	mm	in.	mm
EE3G, EE53G	1.251	31.78	4 ¹⁵ / ₃₂	114	1/4 x 1/4 x 1 ²⁵ / ₃₂	6 x 6 x 45
EE9G, EE59G	1.501	38.13	3 ⁵ / ₁₆	92	3/8 x 3/8 x 1 ¹¹ / ₁₆	10 x 10 x 43

*Tolerance: +0 -.0005" (0.13mm)

KK5B PISTON AIR MOTORS

Round Keyed Shaft • 30 hp • Direct Drive • Flange or Base Mounted

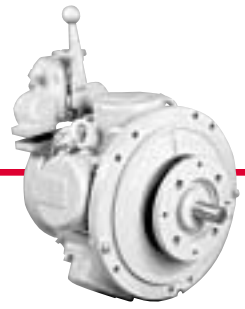

SPECIFICATIONS

Model	Max. Power		Speed at Max. Power	Free Speed▲	Starting Torque		Stall Torque		Air Consumption at Max. Power		Weight	
	hp	kw	rpm	rpm	lb.-ft.	Nm	lb.-ft.	Nm	scfm	m ³ /m	lb.	kg
Reversible												
KK5B546	29	21.6	900	1800	183	248	300	407	795	22.5	—	—
KK5B550	30	22.3	880	1750	202	274	325	441	850	24.1	—	—

▲ ALL models must be operated with sufficient load to prevent speed from exceeding maximum allowable speed shown on performance curve. Performance figures are at 90 psig (620 kPa) air pressure.

KK5B550 – STD ROTARY VALVE

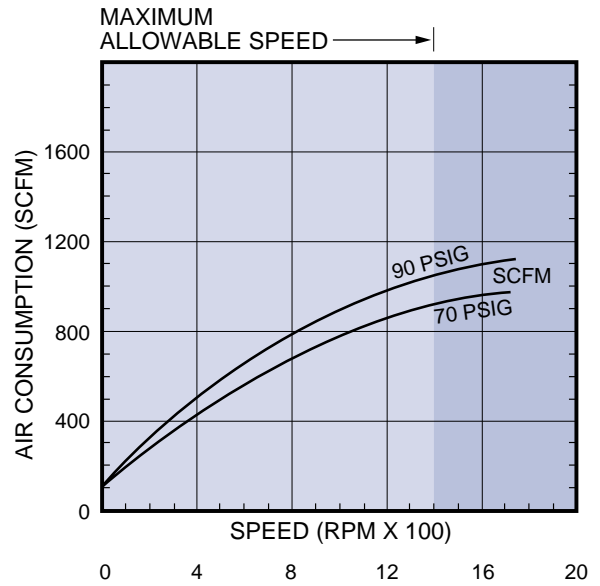
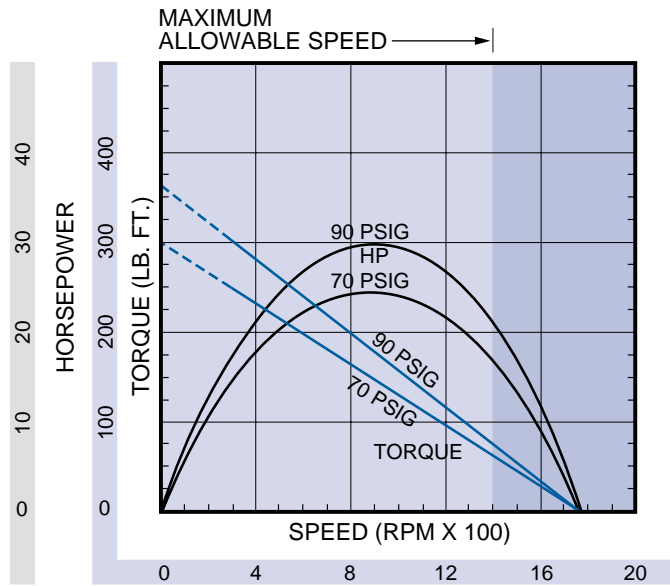

KK5B546 – STD ROTARY VALVE

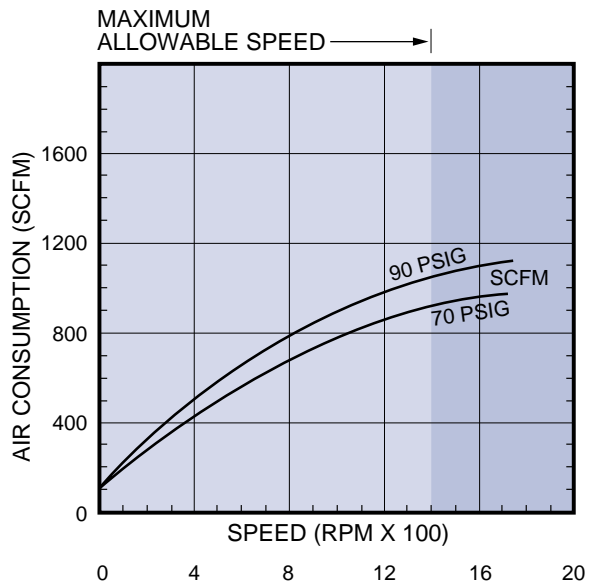
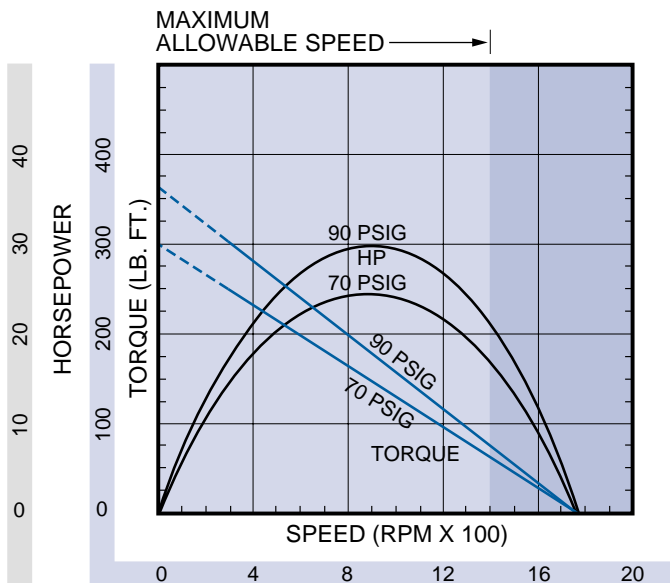

KK5B PISTON AIR MOTORS

KK5B MODEL NUMBER SYMBOLIZATION

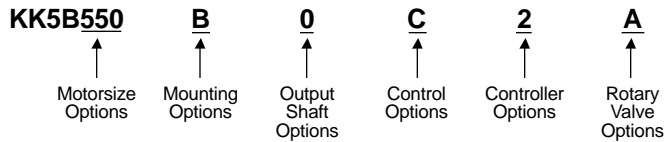

EXAMPLE

KK5B550-B2B0A

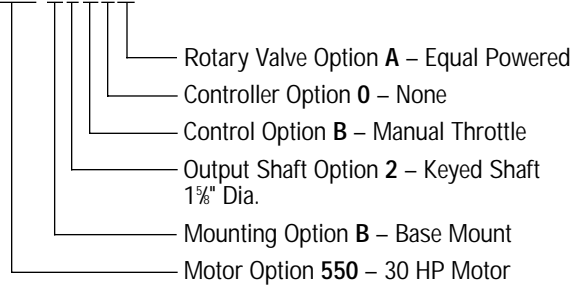

Option	Code	Description	Weight		Part Number
			lb.	kg	
Motor Options	546 550	29 Horsepower Motor 30 Horsepower Motor	251 251	113 113	KK5B546 KK5B550
Mounting Options	A B	Flange Mount, STD with SAE C 2 & 4 Bolt Mount Base Mount, Stationary Mounting	45	20	Standard K5B - Foot
Output Shaft Options	0 1 2	*SAE C, STD with SAE C 14 Tooth Female Spline Input **NEMA 213TC and 215TC, Keyed Shaft 1 3/8" dia. ***Keyed Shaft 1 3/8" dia.	13 24	6 11	Standard K5B - NEMA - 213 K5B - Shaft - 1.625
Control Options	A B C	None Manual Throttle, Control Mounted Directly on Motor Pilot Air Control, Required for Remote Controller Options	19 9	19 4	Standard K5B - Manual K5B - Pilot
Controller Options	0 1 2	None Pendant Control, STD 2 Button Pendant Panel Control, Required for Remote Stationery Mounted Control			Standard MLK-K269C UWD - A686
Rotary Valve Options	A B C	Equal Powered Biased Powered CCW Biased Powered CW			Standard POA POA

*Flange Gasket Required **Single Bearing Mount ***Double Bearing Mount

EXAMPLE KK5B550 - B2A0A ARRANGEMENT

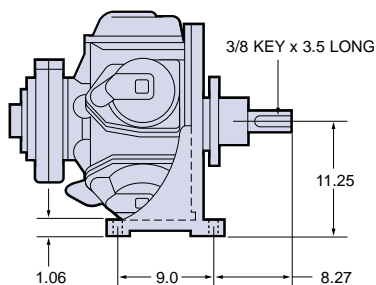

KK5B MOTOR

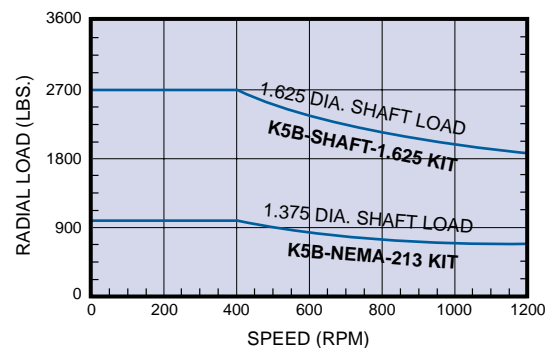

KK5B PISTON AIR MOTORS

Round Keyed Shaft

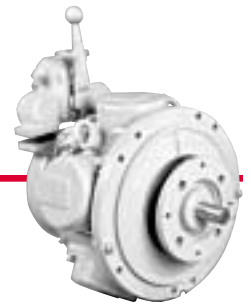

KK5B PISTON AIR MOTOR

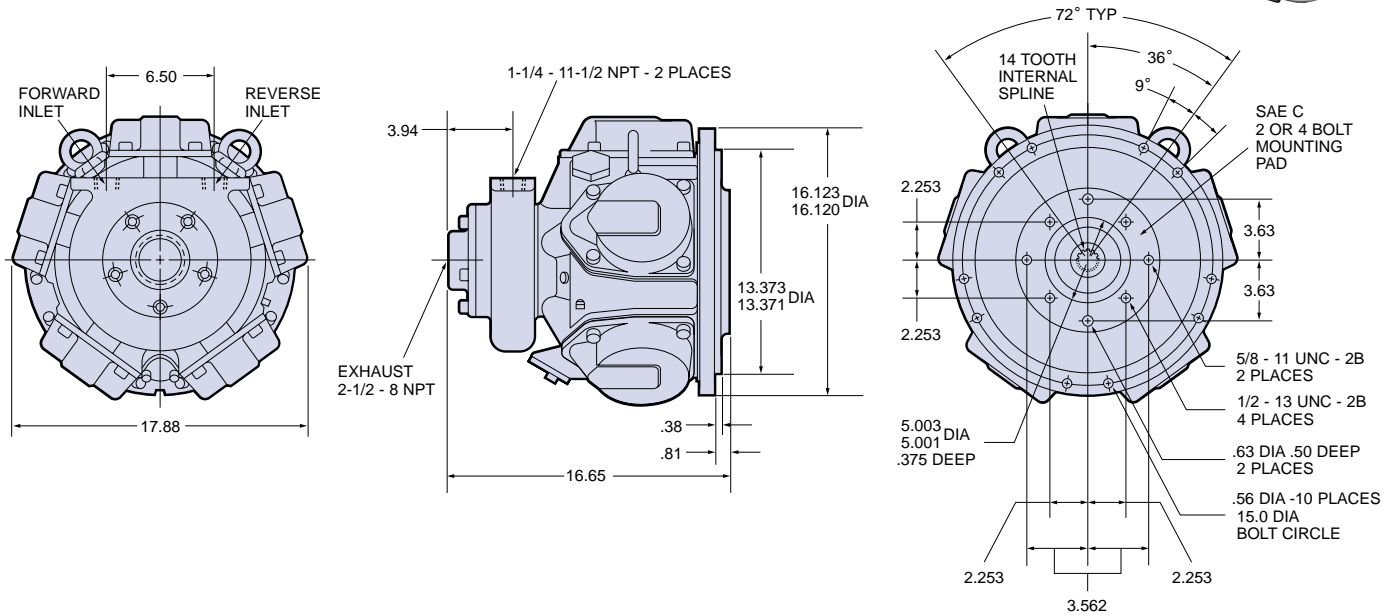

TOP AND SIDE VIEWS

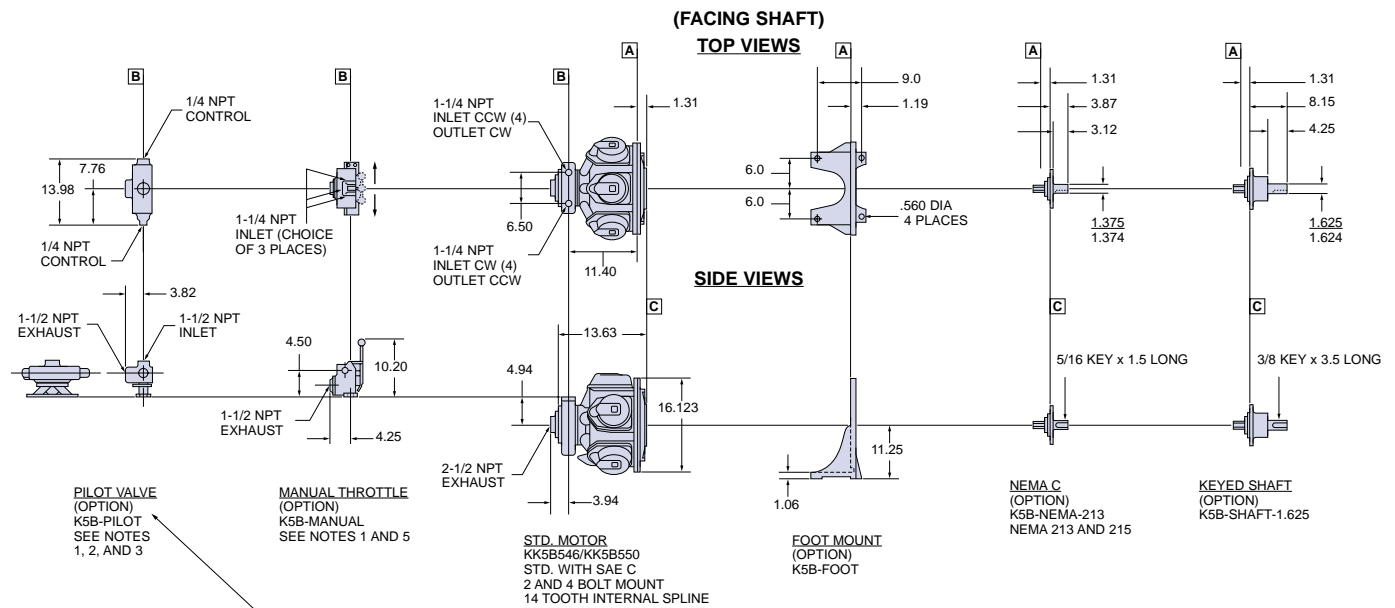

- 1) PERFORMANCE REDUCTION OF 20% - SAME STARTING AND STALL TORQUE BUT REDUCED HORSEPOWER AND FREE SPEED AS VALVING RESTRICTS MAX. AIR FLOW
- 2) FOR CONTROL LINE LENGTHS GREATER THAN 50 FT. AND FOR EVERY 50 FT. THEREAFTER, INSTALL TWO QUICK EXHAUST VALVES IN CONTROL LINES: MK-939-6, 1/4" ID HOSE
- 3) AIR PILOT CONTROLS GIVE GOOD CONTROL UP TO 100 FT. AS THE CONTROL LINES LENGTHEN, THE CONTROL RESPONSE DETERIORATES. ROUTE CONTROL LINES IN THE SHORTEST MANNER PRACTICAL
- 4) CW-CLOCKWISE ROTATION OF MOTOR LOOKING AT OUTPUT SHAFT OR SPLINE CCW-COUNTERCLOCKWISE ROTATION OF MOTOR LOOKING AT OUTPUT SHAFT OR SPLINE
- 5) THE MANUAL THROTTLE MAY BE REMOTELY MOUNTED UP TO 30 FT. AWAY USING EITHER 1-1/2" ID HOSE OR PIPE

MODEL CODE EXPLANATION

Example: MMP150-A-0-B-2-A

MMP150 - A 0 B 2 A

Series: **MMP150 Air Motor**

Interface/Shaft Options:

- A = **Standard Spline**
- B = NEMA 215TC
- C = Hydraulic SAE "B" Adapter
- D = Keyed Shaft (Fenner RM410)

Mounting Options:

- 0 = **Standard**
- 1 = Base Mount

Control Options:

- A = **None**
- B = Manual Valve
- C = Panel Mount Valve
- D = Pendant
- E = Accu-Trol™

Rotary Valve Bias Options:

- 0 = Equal, Bias Rotation*
- 1 = CCW (counter-clockwise), Standard Bias Rotation*
- 2 = **CW (clockwise), Reverse Bias Rotation***

Power Options:

- A = **Air**
- B = Natural Gas

*As viewed from crankshaft end of motor.

PERFORMANCE

Model	Max. Power		Speed at Max. Power	Free Speed	Starting Torque		Stall Torque		Air Consumption at Max. Power	
	hp	kw	rpm		rpm	lb.-ft.	Nm	lb.-ft.	Nm	scfm
MMP 150	16.0	11.9	1800	3800	61.0	82.7	78.0	105.8	425	12.0

Performance figures are at 90 psig (6.2 Bar) air pressure.

**Figure 1: MMP150 Air Motor Performance
425 cfm Air Supply at 90 psi**

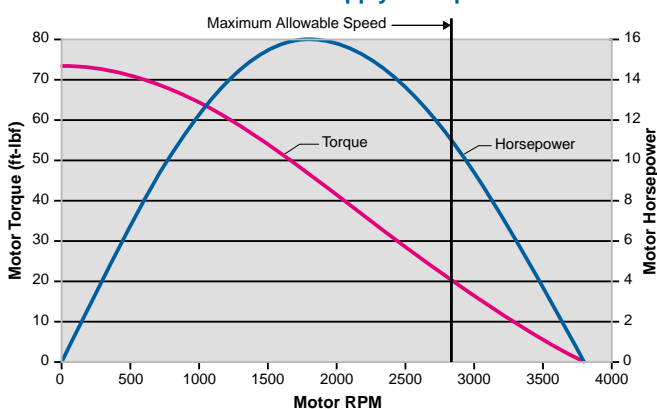
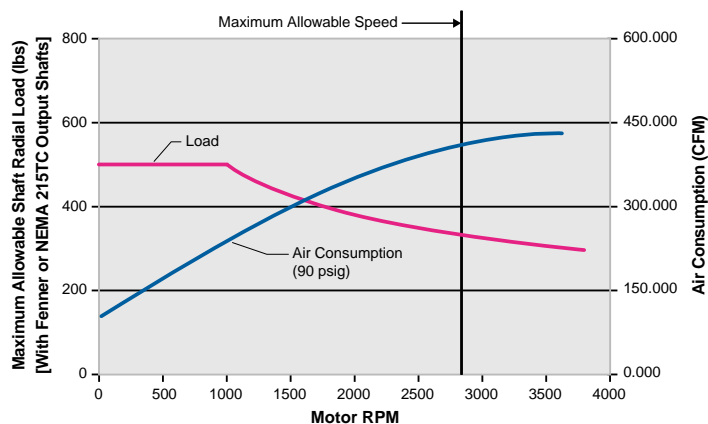
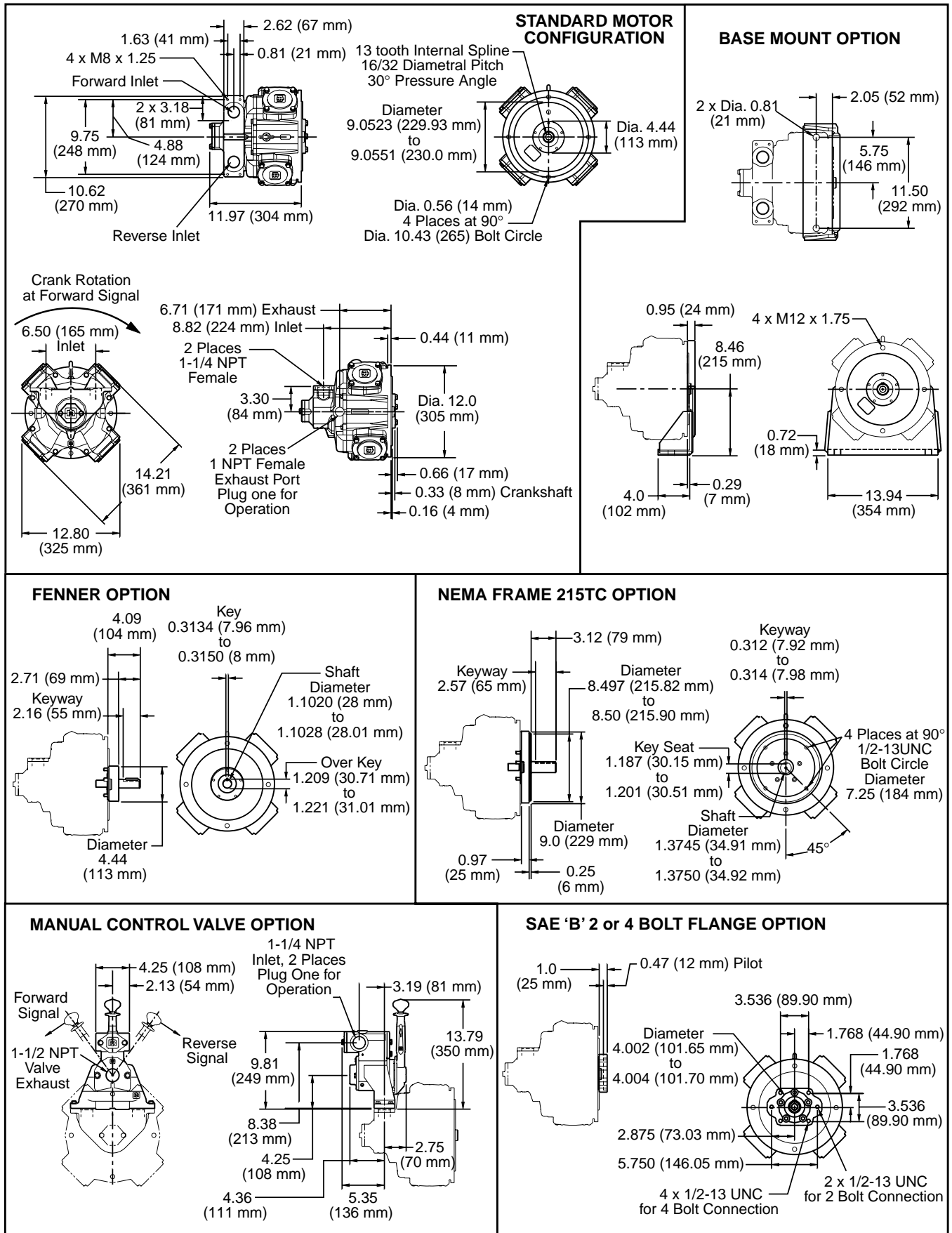

Figure 2: MMP150 Air Motor Performance



MMP150 AIR MOTORS



AIR MOTOR SELECTION AND CHARACTERISTICS

Ingersoll-Rand offers two basic types of Air Motors:

Vane Motors

Are smaller, lighter and less expensive than piston motors of similar power. Simple in design and construction, they can be operated in most any position. Vane motors are available in a broad range of speeds, torques and power and are the most widely used type of air motor.

Radial Piston Motors

Operate at lower speeds than vane motors. Have excellent starting and speed control. Especially good for "lugging" heavy loads at slow speed. Standard operational position is horizontal.

Reversible/Non-Reversible Air Motors

Non-reversible air motors are rated at slightly higher speeds, torques, and horsepowers than reversible motors of the same family.

Air Pressure

When selecting air motors, remember that the specification listings show only one set of performance figures, at a particular pressure—90 psig. Air motors are designed to produce optimum performance at this pressure.

Many other speeds, torques and power can be obtained from the same motor by regulating the pressure, air supply or exhaust. While they will operate at pressures below 40 psig, their performance may not be consistent. They can also be operated above 100 psig, but often at the expense of increased maintenance.

A good rule to follow is to size an air motor based on approximately 70% of the lowest available air pressure. This will allow additional power for starting and possible overloading. See page 50 for performance characteristics at various air pressures.

Maximum Power

Ungoverned air motors develop maximum horsepower at approximately 50% of free (unloaded) speed while governed motors reach their peak horsepower at about 80% of free speed. The only governed motors in this catalog are the 22 and 55 Series listed on pages 26 and 27.

Desired Operating Speed

The desired operating speed, not the free and unloaded speed should be considered when selecting air motors.

Ungoverned air motors should not be run unloaded. The performance curves in this catalog indicate the maximum speeds at which the motor should be operated. The nameplate stamped speed is present for identification only.

Required Torque

Equally important as the speed at which an air motor is to be run is the required torque. The combination of the two factors—speed and torque—determine the power of the desired motor. Care should be taken to differentiate between stall (maximum) and running torques when selecting air motors.

Speed and Torque

Starting torques are approximately 75% of stall torques.

Operating or running torques at any speed can be approximated from motor performance curves—or calculated using the formula:

$$\text{Torque (lb.-ft.)} = \frac{\text{Horsepower} \times 5250}{\text{speed (revolutions per minute)}}$$

$$\text{Torque (Nm)} = \frac{\text{Kilowatts} \times 9550}{\text{speed (revolutions per minute)}}$$

Shaft Radial Loads

When an air motor is to be used with a pulley, sprocket, or gear on the shaft, the overhung load (perpendicular to the shaft), commonly called "shaft radial loading" must be considered. It is shown in the performance curves and is generally assumed to be applied at the mid-point of the keyway of the shaft.

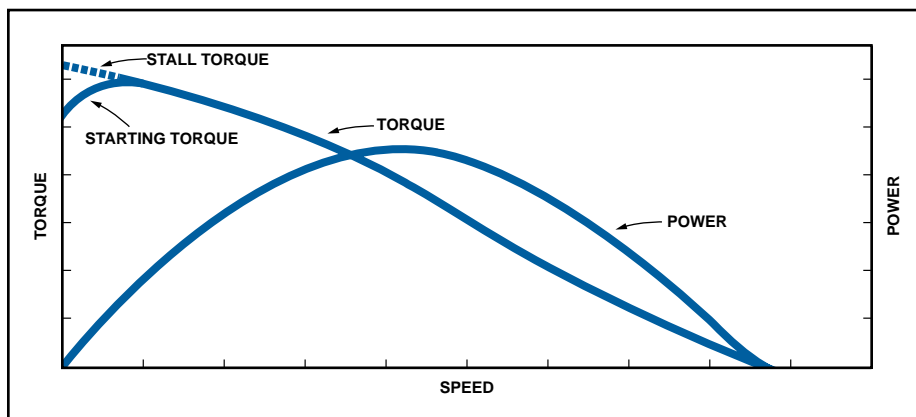

Fig. 1. Torque and power curves for a typical air motor. Torque is maximum at zero speed and zero at free speed. Any loading will slow the motor. As the load increases, the speed decreases and the torque increases until the motor stalls. If the load is decreased, the motor speed increases and its torque output decreases to match the applied load.

AIR MOTOR SELECTION AND CHARACTERISTICS (CONT.)

Air System and Supply

Once an air motor has been selected, it is important to ensure that the desired air pressure is available at the motor, **while the motor is operating**. A pressure reading at the compressor does not mean that the same pressure will be available to an operating air motor, because of possible restrictions and friction losses in the air system. Exhaust restrictions can also affect air motor operation, and are often the cause of performance problems.

Inlet Controls

When installing reversible air motors, a four-way valve or two three-way valves should be used to prevent blockage of the secondary Exhaust Port. This is the opposite Rotation Port to that which is being pressurized.

Replacing Electric Motors with Air Motors

Electric motors, with the exception of series wound direct current motors, have entirely different performance characteristics than air motors. Therefore, their torque and speed curves will not match. Many electric motors are oversized to allow for overloading and lower power air motors can be used as replacements.

Ingersoll-Rand Assistance

Your Ingersoll-Rand Air Motor distributor and factory representative are anxious to help with motor problems, applications and selections.

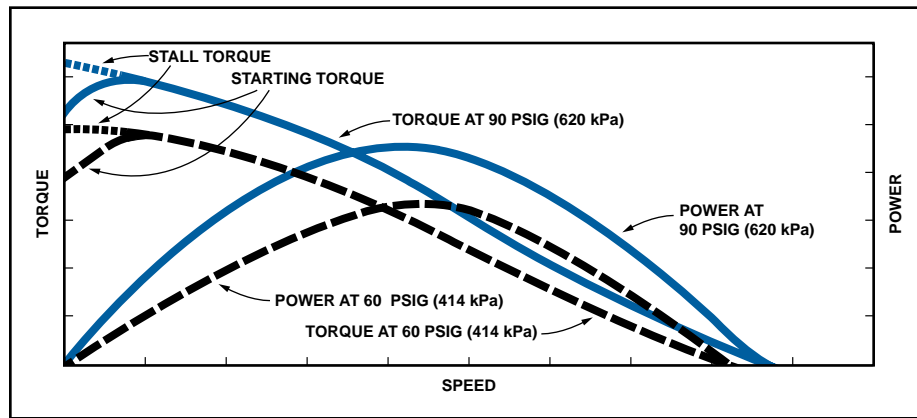

Fig. 2. Typical Air Motor torque and power curves at two different air pressures. Note that speed, torque and power decrease as the air pressure decreases.

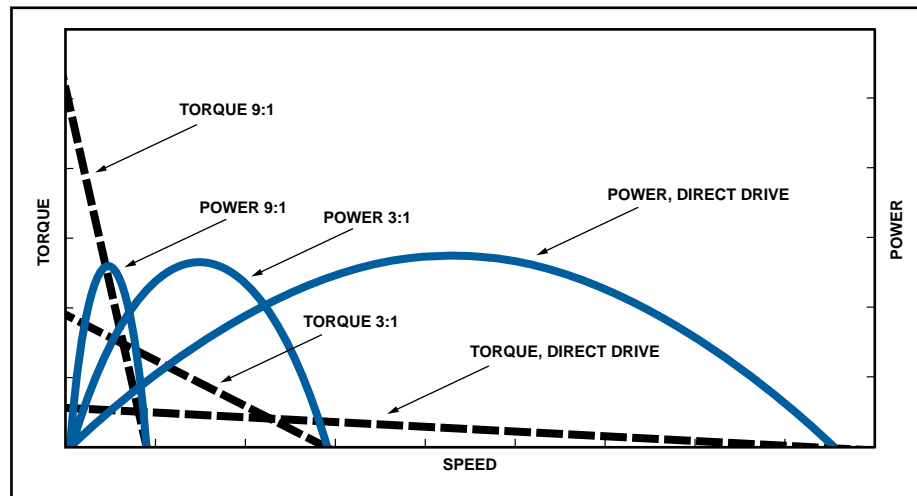

Fig. 3. Torque and power curves for geared and nongear motors. Note that reducing rpm by gearing steepens the torque curve while maintaining power. Gearing is often used to reduce the speed and increase the torque of air motors. The greater the gear reduction, the steeper will be the torque curve; thus, the higher speed motor will be more susceptible to a drop in speed as a load is applied than the slower speed motor with additional gearing.

HOW TO DETERMINE PERFORMANCE CHARACTERISTICS AT AIR PRESSURES OTHER THAN 90 PSIG

As air pressure changes, the performance characteristics will change by the percentages given below.

Ungoverned Air Motors

Air Pressure (psig)	Free Speed (rpm)	Air Consumption at Free Speed (scfm)	Maximum Power (hp)	Speed at Maximum Horsepower (rpm)	Torque at Maximum Horsepower (lb.-ft.)	Air Consumption at Max. Power (scfm)	Stall or Starting Torque (lb.-ft.)
40	80%	45%	30%	80%	37.5%	45%	45%
50	84%	56%	44%	84%	52.4%	56%	56%
60	88%	67%	58%	88%	65.9%	67%	67%
70	92%	78%	72%	92%	78.3%	78%	78%
80	96%	89%	86%	96%	89.6%	89%	89%
90	100%	100%	100%	100%	100.0%	100%	100%
100	104%	111%	114%	104%	109.6%	111%	111%

Example: Knowing the performance characteristics of a Model 3840P reversible ungoverned Air Motor at 90 psig (620 kPa) it is a simple matter to determine its characteristics at another air pressure. Using the percentages from the table for 60 psig (414 kPa), the performance becomes:

Characteristic	Performance At 90 psig	Percentage Reduction	Performance At 60 psig
Maximum Power (hp)	1.35	x 58%	= .78
Free Speed (rpm)	440	x 88%	= 387
Speed at Max Power (rpm)	215	x 88%	= 189
Max (Stall) Torque (lb.-ft.)	53.5	x 67%	= 35.8
Torque at Max Power (lb.-ft.)	33	x 65.9%	= 21.7
Starting Torque (lb.-ft.)	40	x 67%	= 26.8
Air Consumption at Free Speed (scfm)	54	x 67%	= 36.2
Air Consumption at Max HP (scfm)	44	x 67%	= 29.5

Air Supply or Exhaust Regulation

Reducing or restricting the amount of air supplied to the motor has a similar effect to reducing the air pressure.

Choking or restricting the exhaust has a somewhat different effect, with the speed decreasing much more than the torque.

The effects of changes in pressure, air supply and exhaust regulation are summarized in the table at the right:

Exact variations in performance with "choked" motors are not tabulated; however, "on the job" tests will usually produce the desired results; sometimes from a combination of pressure adjustments and inlet and exhaust restrictions.

Air Regulation	Speed	Torque
Reduced air pressure, or restricting volume of air to motor	Reduced	Greatly Reduced
Choking or restricting exhaust	Greatly Reduced	Reduced

FILTERS, REGULATORS AND LUBRICATORS

Ingersoll-Rand and ARO Filters, Regulators and Lubricators give increased Motor performance, reduce repair costs and extend Motor life.

Filters



For Motors	Part No.	NPT Size	Flow Rate scfm	Bowl Cap. oz.	Height in.	Width in.	Depth in.
Series M002, M004, M007, Models MRV003, MOV005AA	F25221-400	¼"	54	2.87	7.00	2.60	2.60
Model MVA008B, Series 1801, 1841	F25231-400	⅜"	100	2.87	7.00	2.60	2.60
Models MRV015, MVA017A, MVA017B, Series 3800, 3840, 4800, 4840, 17RA, 17RB, 48RA, 48RB, Models 22N51, AAM	F25241-400	½"	122	2.87	7.00	2.60	2.60
Models MRV040, MRV050, MVA034A, MVA034B, Series 34RA, 34RB, 551, Models CCM, DD6M	F25451-110	¾"	345	32.00	11.70	4.75	4.75
Model MOV075AA, Series 92RA, 92RB, 92RM, 992RM, Models EEM, EE5M, HHM, EE3G, EE9G, EE53G, EE59G	F25461-110	1"	345	32.00	11.70	4.75	4.75
Models HH5M, KK6M	F42-0A-000	1½"	860	13.00	14½"	8½"	8½"
Models KK5B546, KK5B550	F35-0B-C28	1½"	1280	12.50	19.07	7.80	7.75

Regulators



For Motors	Part No.	NPT Size	Flow Rate scfm	Adj. Pressure Range psi	Height in.	Width in.	Depth in.
Series M002, M004, M007, Models MRV003, MOV005AA	R27221-600	¼"	100	0 - 200	4.75	2.60	2.60
Series 1801, 1841	R27231-600	⅜"	130	0 - 200	4.75	2.60	2.60
Models MRV015, MVA017A, MVA017B, Series 3800, 3840, 4800, 4840, 17RA, 17RB, 48RA, 48RB, Models 22N51, AAM	R27241-600	½"	150	0 - 200	4.75	2.60	2.60
Models MRV040, MRV050 Series 551, Models CCM, DD6M	R27251-100	¾"	180	5 - 250	7.10	4.25	4.25
Models MVA034A, MVA034B, Series 34RA, 34RB	R38-06-F0G0-28	¾"	491	0 - 125	7.83	3.94	3.94
Model MOV075AA, Series 92RA, 92RB, 92RM, 992RM, Models EEM, EE5M, HHM, EE3G, EE9G, EE53G, EE59G	R38-08-F0G0-28	1"	491	0 - 125	7.83	3.94	3.94
Models HH5M, KK6M	R30-0A-G00	1½"	800	0 - 125	10.30	4.30	4.30
Models KK5B546, KK5B550	R40-0B-G00	1½"	1200	0 - 125	11.90	5.30	5.30

Lubricators



For Motors	Part No.	NPT Size	Flow Rate scfm	Bowl Cap. oz.	Height in.	Width in.	Depth in.
Series M002, M004, M007, Models MRV003, MOV005AA	L26221-100	¼"	75	6.00	7.70	2.60	2.60
Series 1801, 1841	L26231-100	⅜"	100	6.00	7.70	2.60	2.60
Models MVA017A, MVA017B, Series 17RA, 17RB,	L26241-100 * ½" connection	½"	110	6.00	7.70	2.60	2.60
Models MRV015, 22n51-W/RC, Series 3800, 3840	L28-04-LK00-28	½"	184	6.11	9.36	2.39	2.39
Models 4800, 4840, 48RA, 48RB	L26251-110 * ¾" connection	½"	190	32.00	11.70	4.75	4.75
Models MRV040, MRV050, MVA034A, MVA034B, Series 34RA, 34RB, 551, Models CCM, DD6M	L28-06-LK00-28	¾"	200	6.11	9.36	2.90	2.90
Model MOV075AA, Series 92RA, 92RB, 92RM, 992RM, Models EEM, EE5M, HHM, EE3G, EE9G, EE53G, EE59G	L38-08-LL00-28	1"	440	19.00	10.67	3.94	3.94
Models HH5M, KK6M	L40-0A-000	1½"	927	26.00	11.61	5.50	5.00
Models KK5B546, KK5B550	L40-0B-000	1½"	927	26.00	11.61	5.50	5.00

AIR MOTOR COMPONENTS AND EQUIPMENT

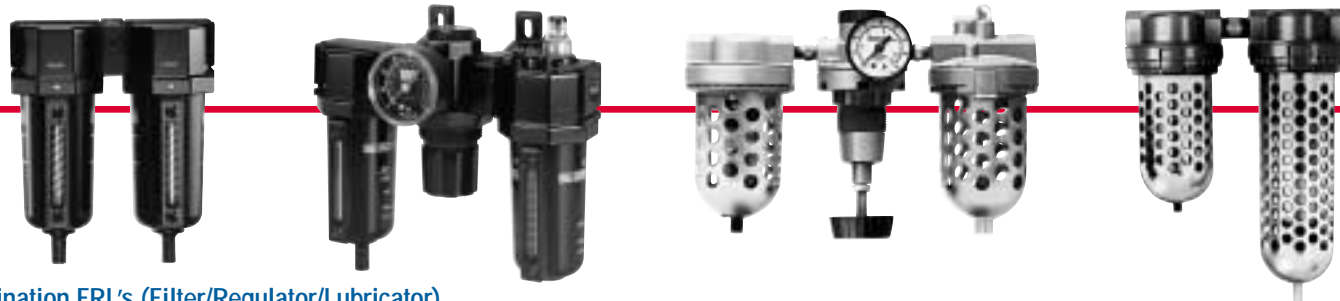

Combination FRL's (Filter/Regulator/Lubricator)

For Motors	Part No.	NPT Size	Flow Rate scfm	Adj. Pressure Range psi	Bowl Capacity oz.	Height in.	Width in.	Depth in.
Series M002, M004, M007, Models MRV003, MOV005AA	C28221-800	1/4"	54	0 - 125	Filter = 2.87 Lubricator = 6.00	8.25	9.43	4.00
Series 1801, 1841	C28231-800	3/8"	100	0 - 125	Filter = 2.87 Lubricator = 6.00	8.25	9.43	4.00
Models MRV015, 22N51 Series 3800, 3840, 17RA, 17RB	C28241-800	1/2"	110	0 - 125	Filter = 2.87 Lubricator = 6.00	8.25	9.43	4.00
Models MVA017A, MVA017B, Series 4800, 4840, 48RA, 48RB, 17RA, 17RB,	C28-04-FKG0-28	1/2"	135	0 - 125	Filter = 2.87 Lubricator = 6.11	11.44	6.10	4.35
Models MRV040, MRV050, Series 551, Models CCM, DD6M	C28453-810	3/4"	180	0 - 125	Filter = 32.0 Lubricator = 32.0	15.25	11.75	11.75
Model MVA034A, MVA034B, 34RA, 34RB	Must use individual units or 1" model	3/4"	—	—	—	—	—	—
Model MOV075AA, Series 92RA, 92RB, 92RM, 992RM, Models EEM, EE5M, HHM, EE3G, EE9G, EE53G, EE59G	C31-08-G00	1"	331	0 - 125	Filter = 2.0 Lubricator = 26.0	11.20	15.30	5.70

LIQUIDATOR FILTERS

You can depend on Ingersoll-Rand and ARO Liquidator Filters™ when you need clean, dry air and your regular filter can't handle high volumes of liquid contaminants. Note that a lubricator should be installed between the Air Motor and the Liquidator.

Features

Two stage filtration cartridges remove 99% of liquid contaminants. Four micron filter element removes 99% of all dirt particles 4 microns or larger. Quick release bowls enable easy cartridge replacement. Automatic first stage float drain with manual override. Manual second stage flex-drain. Clear polycarbonate bowl with metal guard provides for quick inspection.

Benefits

Reduces liquid contaminants.
Increases Air Motor life.
Cuts maintenance costs.

Liquidator Filters

Female NPT	IR Part Number	Flow Rate scfm	Female NPT	ARO Part Number	Flow Rate scfm
1/4"	8842-W1-035	35	1/4"	F25221-300	40
3/8"	8843-W1-035	35	3/8"	F25231-300	51
1/2"	8844-W1-090	90	1/2"	F25241-300	53
3/4"	8846-W1-090	90	3/4"	F25452-310	50
1"	8828-W2-000	175	1"	F25462-310	150
1 1/4"	8830-W1-000	400	1 1/4"	F25472-310	150
2"	8834-W1-000	700	—	—	—

LUBRICATION

Proper lubrication of Air Motors is a must to prevent excessive wear of moving parts; to prevent possible rust and corrosion of bare, unprotected surfaces. Ingersoll-Rand oils and greases have been tested thoroughly and are recommended without reservation. Refer to Operation Manuals and Parts Lists for lubrication instructions.

Oils

Part Number	Oil Number	Quantity	Recommended Use
10P 10G	10	1 pt 1 gal	Fractional horsepower Air Motors
50P 50G	50	1 pt 1 gal	One horsepower and larger Air Motors

Greases

Part Number	Grease Number	Quantity lb.	Recommended Use
28 1 LB 28 8 LB	28	1 8	Motor gearing and bearings

SELF-CLOSING VALVES

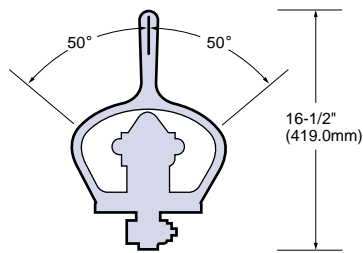

NO. EU-A685

Self-Closing 4-Way Valve. Air inlet pipe tap $\frac{3}{4}$ " NPT, Motor connection pipe tap 1" NPT, exhaust pipe tap $\frac{3}{4}$ " NPT.

MUFFLERS

Part Number	MALE NPT Size
MRV003A-AF350**	$\frac{1}{8}$ "
MRV015A-AC980*	$\frac{1}{4}$ "
SRA010A1-A212***	$\frac{3}{8}$ "
MRV040A-AC990**	$\frac{1}{2}$ "
MOV010AA-674*	$\frac{1}{2}$ "
3BM-WM07	$\frac{3}{4}$ "
3BM-A674*	1"
150BM-A674*	$1\frac{1}{4}$ "
SS350-A674*	$1\frac{1}{2}$ "
ST500-674	2"
SS800-A674*	$2\frac{1}{2}$ "

* High scfm Capacity
 ** Medium scfm Capacity
 *** Low scfm Capacity

$\frac{3}{8}$ " SQUARE DRIVE ADAPTERS

These $\frac{3}{8}$ " Square Drive Adapters have a $\frac{3}{8}$ "-24 female thread, for use with Series M002 and M004 Motors equipped with threaded shafts.

Part Number	Description
R1440-212-1	$\frac{3}{8}$ " square drive, 1" long
R1440-212-3	$\frac{3}{8}$ " square drive, 3" long

NO. K5B-REMOTE

Self-closing 4-Way Valve. Air inlet pipe tap $1\frac{1}{2}$ " NPT, Motor connection pipe tap $1\frac{1}{2}$ " NPT, exhaust pipe tap

1 $\frac{1}{2}$ " NPT. MOUNTING FEET

Motor	Part Number
MRV003A	MRV003A-AG587
MRV005C	MRV003A-AG587
MRV009C	MRV015B-AH636
MRV015A	MRV015A-AH634
MRV040A	MRV015A-AH634
MRV050A	MRV050A-AH640
MVA017B	MVA008-K4
MVA034B	MVA008-K4

TAPPED EXHAUST DEFLECTORS FOR PIPED AWAY EXHAUST

Motor Series	Part Name	Part Number	Pipe Tap NPT
1801 1841	Exhaust Deflector Assembly	R1801-A123	$\frac{3}{4}$ "
3800 3840	Exhaust Deflector Assembly	R3800-A123	$\frac{3}{4}$ "
4800 4840	Exhaust Deflector Assembly	R4800-A123	1"

"SPECIAL" AIR MOTORS

While there are over 300 standard Air Motors in the complete Ingersoll-Rand line, we realize that even this broad selection won't fill every need, every time. Virtually all components of our motors, from output shafts and housings to gear ratios, can be modified. Therefore we welcome the opportunity to design and build Air Motors to our customers' specifications when required.

Generally, yearly quantities of 100 plus are cost-effective. However, the opportunity to quote on lower volumes is always welcomed.

Frequently custom designed Air Motors can reduce OEM costs by easing product assembly, increasing performance, and avoiding the need to make special parts to incorporate the Air Motor in a product. We have the engineering capabilities to provide you with truly "turnkey" power units.

If you find you need Air Motors to meet special requirements, please complete the Air Motor profile sheet on page 55, and mail it to: Ingersoll-Rand, PO Box 8000, Southern Pines, NC 28388, or call 1-910-692-8700.

Productivity Solutions Contact Information

North American Facilities

North American Sales Office

Ingersoll-Rand
Business Development Center
PO Box 970, 1467 Route 31 South
Annandale, NJ 08801
Telephone: (908) 238-7000
Fax: (908) 238-7053

Manufacturing

Ingersoll-Rand
1725 US #1 North
Southern Pines, NC 28387
Phone: (910) 692-8700
Fax: (910) 692-8013

Distribution

Ingersoll-Rand
510 Hester Drive
White House, TN 37188
Telephone: (615) 672-0321
Telefax: (615) 672-0801

Canada National Sales Office

Ingersoll-Rand
51 Worcester Road
Toronto, Ontario M9W 4K2
Telephone: (416) 213-4500
Telefax: (416) 213-4510

International Facilities

Latin America

Ingersoll-Rand
730 N.W. 107th Avenue, Suite 300
Miami, FL 33172-3107
Telephone: (305) 559-0500
Telefax: (305) 222-0864

Europe

Ingersoll-Rand
Zone du chene Sorcier
B.P. 62
78346 Les Clayes sous Bois Cedex
France
Telephone: (33) 1 30 07 69 39
Telefax: (33) 1 30 07 69 81

Asia/Pacific

Ingersoll-Rand
23/F., 625 King's Road, North Point
Hong Kong
Telephone: (852) 2527 0183
Telefax: (852) 2529 5976

Customer Service – (866) 474-8665

Technical Support – (800) 866-5457

www.airmotors.com



Ingersoll-Rand
Productivity Solutions
1725 U.S. Hwy #1-N
Southern Pines, NC 28387
www.airmotors.com